

# HYPERION EOS 5i DP AC/DC

## User's Manual



Power, with Ease

# HYPERION EOS 5i DP AC/DC - User's Manual

*Please read the following instructions carefully, to insure safety and convenience*

## EOS 5i DP AC/DC Special Features

- \*Two INPUT power choices: Use AC 100~240V at home, or DC 11~15V anywhere
- \*Powerful, yet compact and portable with Wide support for various battery types
- \*Clear and easily readable LCD Screen with Warning messages for common setup errors
- \*Packaged in a rugged aluminum case - Output harness included - Long Input leads
- \*Specially designed to be 100% Compatible with Li-Po PCM Guard and Balancer Adapters
- \*DataPort Interface for EOS LBA 10 Balancers (see last page of manual for details)

## Specifications

Input voltage range	100~240V AC OR 11.0-15.0V DC (only one source may be connected at a time!)
Appropriate battery types and range of series-connected cells	1-14 Nickel-Cadmium cells
	1-14 Nickel-Metal Hydride cells
	1-5 Lithium cells, 100~5000mAh (3.7V/cell type)
	1-6 Lead-Acid cells (2V per cell nominal)
Charge current	0.1A ~ 5A MAX, by 100mA steps
Discharge current	0.1A ~ 1A MAX, by 10mA steps
Trickle charge current (NiCd, NiMH)	0 ~ 200mA
Charge termination	"zero delta V" peak detection for NiCd/NiMH
	"CV/CC" for Lithium and Lead-Acid Batteries
Cycling Modes (NiCd, NiMH)	Charge>Discharge and Discharge>Charge
Display type	2-line, 16 backlit character LCD

## Safety precautions

- **KEEP CHARGER AWAY FROM CHILDREN AND PETS AT ALL TIMES!**
- This charger is designed **ONLY** for NiCd, NiMH, Lithium (3.7V/cell), Lead-Acid (2.0V/cell) type cells. **DO NOT** attempt to charge other types, such as 3.6V/cell Lithium, or non-rechargeable batteries!
- Always place the charger on a firm, level, and fireproof surface for charging.
- Do not place the battery or charger on or near flammable materials while in use. Keep away from carpets, cluttered workbenches, etc.
- Do not exceed cell manufacturer's suggested max charge rates
- Do not use automotive type battery chargers to power the charger.
- Do not leave the charger unattended while charging.
- Disconnect the battery and remove input power from charger immediately if the charger becomes hot. Allow the charger or battery to cool down before reconnecting.
- Do not allow water, moisture or foreign objects into the charger.
- Do not open the charger, nor attempt any repair. It is dangerous, and will void your warranty.
- Do not obstruct the air intake holes on the charger.
- ALWAYS follow correct connection sequence, as given below

**CAREFULLY FOLLOW THE BATTERY PACK MAKER'S RECOMMENDATIONS AND SAFETY ADVICE!**

### **Using the EOS 5i DP AC/DC**

The EOS 5i includes an Output Harness with two 4mm male "banana" connectors attached. First, solder your chosen battery connector to the bare wire ends of the harness, taking great care to observe proper polarity.

ALWAYS FOLLOW this connection sequence, and reverse sequence to disconnect:

1) Connect OUTPUT harness to the sockets located on the right side of the charger.

Take care that the Output Harness RED wire bullet connector goes to the (+) socket, and BLACK wire to (-) .

2a) Connect Charger INPUT alligator clips to an appropriate DC power source:

a) A 12V automobile battery

b) A quality, low-noise DC power supply of 12~15V with 5A+ rating (large batteries may require 10A supply)

**OR**

2b) Connect to AC wall power 100~240V using the supplied AC adapter cable

**DO NOT CONNECT BOTH AC AND DC INPUT AT THE SAME TIME!!**

The Charger will display INPUT VOLTAGE error message if input voltage is out of range. If this happens, please recheck the input power supply to make sure correct voltage is present.

3) Set the battery type using the charger configuration buttons.



\*The **INC** and **DEC** buttons are used to **Increase** or **Decrease** values, such as Charge Current or LiPo Cell Count

\*The **INC** and **DEC** buttons are used to select **MODE**, such as Charge, Discharge, or Cycle

\*The **BATT TYPE** and **ENTER** buttons both have two modes: SHORT press or LONG (~1 second) press

- Short press **BATT TYPE**: Scroll battery types
- Long press **BATT TYPE**: View input/output Data
- Short press **ENTER**: Scroll settings for a battery type. Values will blink when selected. If nothing is changed, blinking will stop. Short press Enter until re-selected, then INC/DEC to change values.
- Long press **ENTER**: START charging (or discharging, or cycling)

**Let's start by using a NiMH battery as an example:**

When the charger is first connected to input power, it will display the previously used battery configuration.

This is especially convenient if you often charge the same type of battery.

**1) If NIMH is not shown, short push the BATT TYPE button to scroll through all battery types. Stop when you reach NIMH.**

**2) Short press the ENTER button to select "C", charge rate in Ampere**

**3) Press INC or DEC buttons to choose the proper rate for your battery pack.**

Charging NiCd and NiMH is mostly automatic, and the setup routines are the same for both. You only need to consult the documentation for your battery pack (or ask your dealer) to determine the proper charge current in Ampere (A). If the rate is given in mA, note that 100mA equals 0.1A: so 900mA would be 0.9A, for example.

**4) Attach your NiMH battery to the EOS 5i Output side harness, checking that +/- polarity is correct.**

**5) Long press ENTER button (hold down for about 1 second) to begin charging**

NO BATTERY error - if battery not connected

OPEN CIRCUIT error - if the battery becomes disconnected from the charger after START

REVERSE POLARITY error - if the battery is connected in reverse

In our NiMH charging example above, we pressed the **ENTER** button when "NiMH" was blinking, to go directly to charge rate setting. However, if you want to enter **DISCHARGE** or **CYCLE** modes, you can press the **BATT TYPE** button to start **NiMH** blinking, then press **INC/DEC** buttons to scroll through the various modes. Once the mode is settled (like **CYCLE**), short press **ENTER** to start values blinking for editing.

Below are the flow charts for all the settings in the charger. Have a play with no battery connected, to see how to set all the parameters, for all supported battery types.

### NiCd Mode

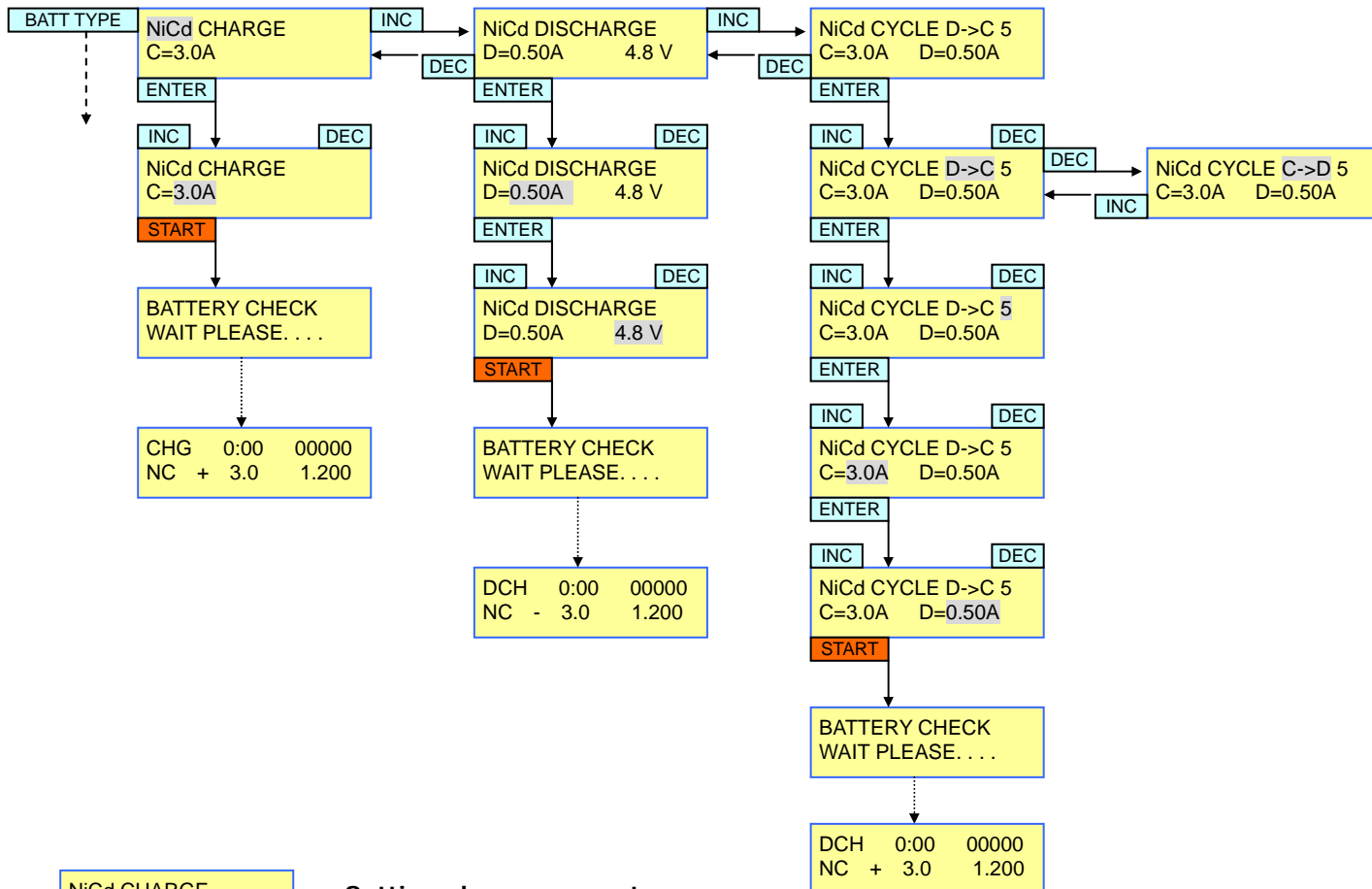

NiCd CHARGE  
C=3.0A

#### Setting charge current

Adjust and find the desired charge current which ranges from 0.1A to 5.0A with INC & DEC buttons. Press the ENTER button to confirm setting.

NiCd DISCHARGE  
D=0.50A 4.8 V

#### Setting discharge current

Adjust and find the desired discharge current, ranging from 0.1A to 1A, with INC & DEC buttons. Press the ENTER button to confirm setting.

NiCd DISCHARGE  
D=0.50A 4.8 V

#### Setting discharge cutoff voltage

This is the voltage that the charger should stop discharging the battery. Adjust and find total discharge cutoff voltages to be discharged from 0.1V to 16.8V with INC & DEC buttons. Press the ENTER button to confirm setting.

NiCd CYCLE C->D 5  
C=3.0A D=0.50A

#### Setting cycle

This is to set cycling with two options ( Charge to Discharge / Discharge to Charge). Set cycling with INC & DEC buttons, and press the ENTER button to confirm setting.

# NiMH Mode

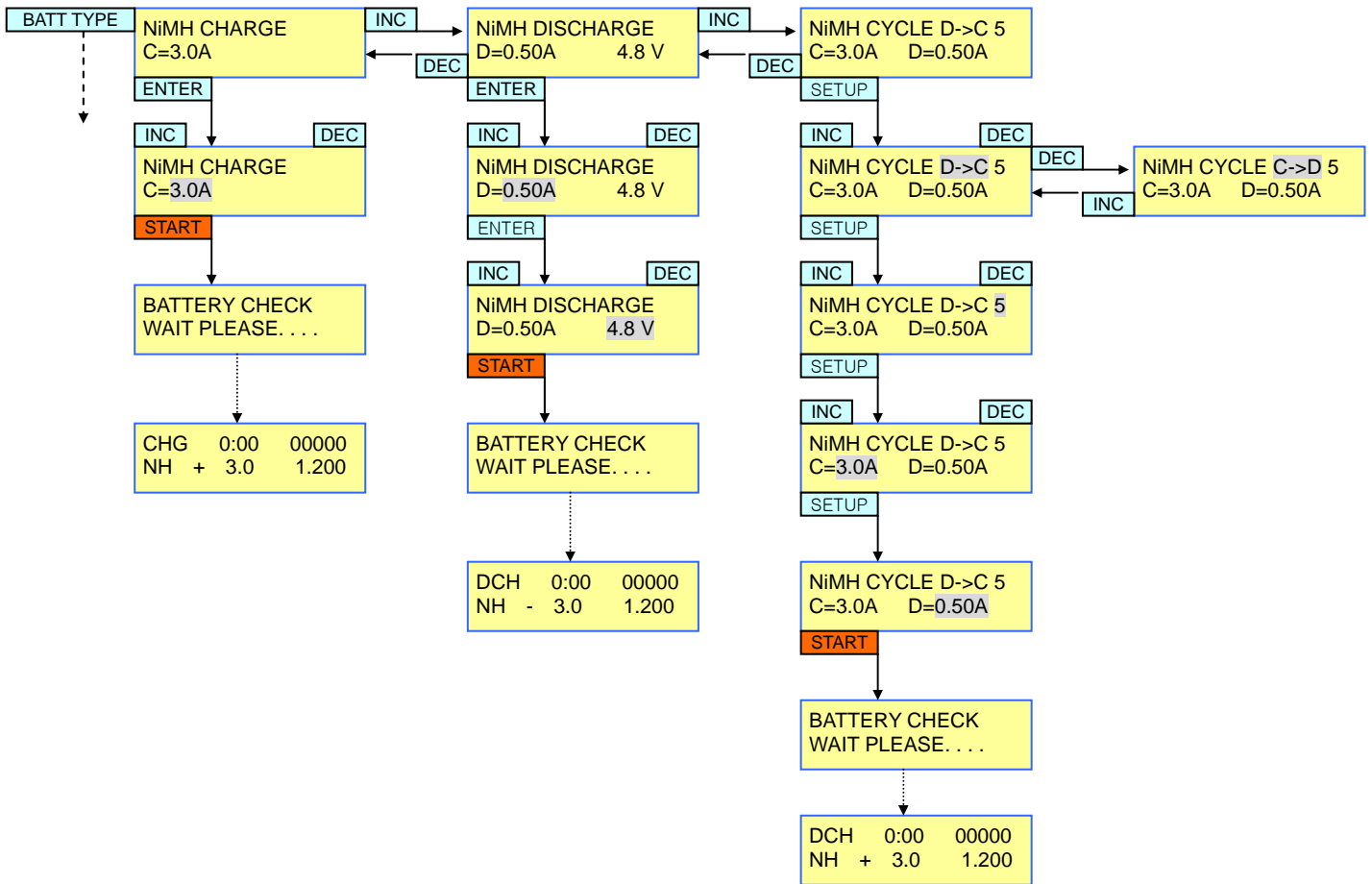

NiMH CHARGE  
C=3.0A

## Setting charge current

Adjust and find the desired charge current which ranges from 0.1A to 5.0A with INC & DEC buttons. Press the ENTER button to confirm setting.

NiMH DISCHARGE  
D=0.50A 4.8 V

## Setting discharge current

Adjust and find the desired discharge current which ranges from 0.1A to 1A with INC & DEC buttons. Press the ENTER button to confirm setting.

NiMH DISCHARGE  
D=0.50A 4.8 V

## Setting discharge cutoff voltage

This is the voltage that the charger should stop discharging the battery. Adjust and find total discharge cutoff voltages to be discharged from 0.1V to 16.8V with INC & DEC buttons. Press the ENTER button to confirm setting.

NiMH CYCLE C->D 5  
C=3.0A D=0.50A

## Setting cycle

This is to set cycling with two options ( Charge to Discharge / Discharge to Charge). Set cycling with INC & DEC buttons, and press the ENTER button to confirm setting.

## Lithium Mode (for 3.7V/cell types only!)

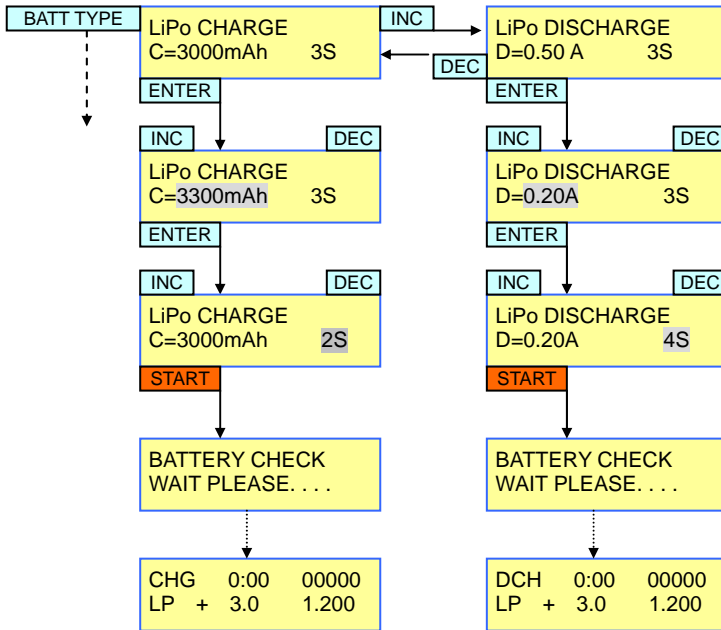

### Setting Lithium battery capacity

LiPo CHARGE  
C=3000mAh 2S

Adjust and set the desired battery capacity from 100mAh to 5000mAh with INC & DEC buttons (50mAh per step). Press the ENTER button to confirm setting. Charge rate is set on the basis of selected capacity, at 1C rate. Example : Li-Po cell of 1500mAh capacity : 1C = 1500mAh ( = 1.5A ). If your battery is larger than 5000mAh, you can charge it at the 5000mAh setting, but it will just take longer to finish charging.

LiPo CHARGE  
C=3000mAh 3S

### Setting battery voltages for Lithium battery packs

Select the total battery voltage to be charged or discharged with INC & DEC buttons: 1S=

1S = 3.7V - single cell

2S = 7.4V - two-cell series pack

3S = 11.1V - three-cell series pack

4S = 14.8V - four-cell series pack

5S = 18.5V- five-cell series pack

**NOTE:** The EOS Series chargers have intelligent detection routines to help you avoid making mistakes, and LOW or HIGH VOLTAGE errors are displayed if battery voltage does not match your setting. HOWEVER, under some circumstances, especially with over-discharged or damaged batteries, the safeguard could fail. *Therefore, be absolutely sure that you have correctly set pack voltage correctly before charging, every time!*

LiPo DISCHARGE  
D=0.50 A 3S

### Setting discharge parameters

Adjust to the desired discharge current from 0.10A to 1.00A (0.01A per step) with INC & DEC button. Press the ENTER button to confirm setting. Set pack voltage, 1S~5S as in charging example above. Autocut occurs automatically at 3.0V per cell.

**LITHIUM MODE IS ONLY FOR LITHIUM BATTERIES WITH 3.7V/cell RATING! Some Li-Ion types are rated at 3.6V/cell, and CANNOT BE CHARGED with the EOS 5i!**

## Pb Mode (lead-acid battery)

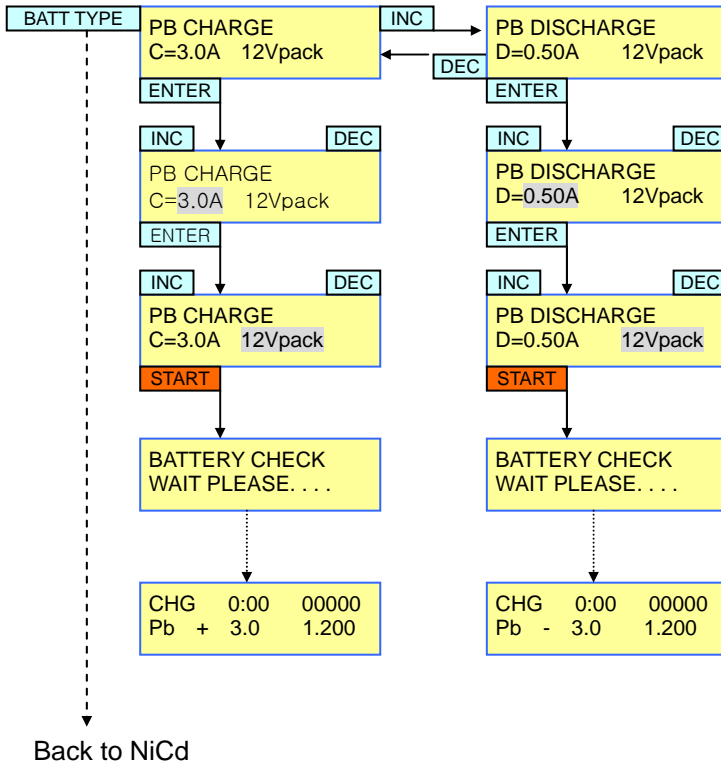

PB CHARGE  
C=3.0A 12Vpack

### Setting charge current

Adjust and find the desired charge current which ranges from 0.1A to 5.0A with INC & DEC buttons. Press the ENTER button to confirm setting

PB CHARGE  
C=3.0A 12Vpack

### Setting total battery voltage for Lead-Acid Battery

Select the proper total battery voltage to be charged or discharged with INC & DEC buttons – 2V, 4V, 6V, 8V, 10V, and 12V [2V per cell types only]

PB DISCHARGE  
D=0.50A 12Vpack

### Setting discharge current

Adjust and find the desired discharge current from 0.10A to 1.00A (0.01A per step) with INC & DEC button. Press the ENTER button to confirm setting.

## Displays during charge, discharge, and cycle

CHG: charge  
DCH: discharge  
C→D: cycle  
D→C: cycle

CHG 030:25 00000  
NC + 3.00A 10 .75V

DCH 030:25 00000  
NC - 3.00A 10 .75V

DELAY TIME  
5 : 00

NC: NiCd  
NM: NiMH  
LP: LiPo  
Pb: Pb

## Completion display

If the Enter button is pressed , charge or discharge will be stopped.

```
END 030:00 00000  
NC 100mA 10.75V
```

In order to move back to the main display, press the Enter button.

## Data display

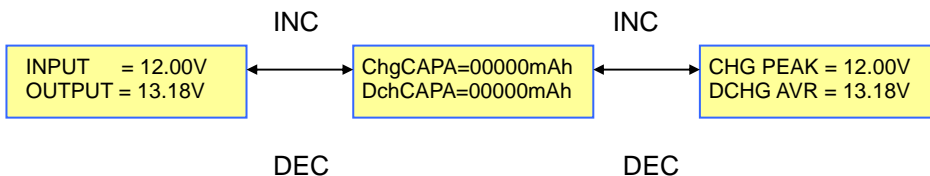

If the Battery type button is pressed for over 3 seconds, Data view will be displayed as above. Data displays can be scrolled left and right by INC & DEC buttons. If nothing pressed for 3 seconds, this display disappears.

## Error messages

```
INPUT BATTERY  
VOLTAGE ERROR
```

When input voltage is below 11.0V or exceeds 15V.

```
NO BATTERY
```

Battery is not connected to the charger's output

```
OUTPUT BATTERY  
REVERSE POLARITY
```

Battery is connected to the output in reverse

```
OUTPUT CIRCUIT  
PROBLEM
```

When the output connection has some other problem

```
CHECK THE BATT.  
OPEN CIRCUIT
```

When a battery becomes disconnected during an operation

```
CHECK THE BATT.  
OVER VOLTAGE
```

If incorrect voltages are set while charging lithium or Pb batteries.

```
CHECK THE BATT.  
LOW VOLTAGE
```

If incorrect voltages are set or batteries are over discharged while charging Lithium or Pb batteries.



## LBA DATAPORT FEATURE

The DataPort is a 3-pin output which fits the option cable #HP-EOSLBA10-DPC. See top label to locate the DataPort on the top left side of your EOS charger. There are two main functions of the DataPort connection to LBA10 balance adapter:

- \*The LBA communicates with the charger, giving notification when balance charging is completed, or when an error is detected. In both cases, the LBA tells the charger to shut down. This insures maximum safety, and saves the user from having to manually push the charger STOP (enter) button to stop the charge-end or error tones. The lithium battery should be disconnected from the LBA as soon as possible after charging is completed.

- \* The DataPort version EOS chargers, when connected to LBA10 balancer via cable #HP-EOSLBA10-DPC, allow the user to monitor the individual voltages of each battery cell during the charge process. This is an important addition to pack diagnostics, as one is able to see the exact balance status of the battery pack (or packs, when LBA10 is in NET mode).

To view individual cell voltages after the balance charge has been started:

- \* Connect DataPort Cable (DPC) between Charger and LBA10 as shown by the Green line in diagram below. [no matter if single or networked LBA, connect DPC to Master LBA]

- \*Push the EOS5i BATT TYPE Button for 3 seconds to access DATA screen.

- \*Push the INC, DEC buttons to scroll up and down data screens as in the chart below.

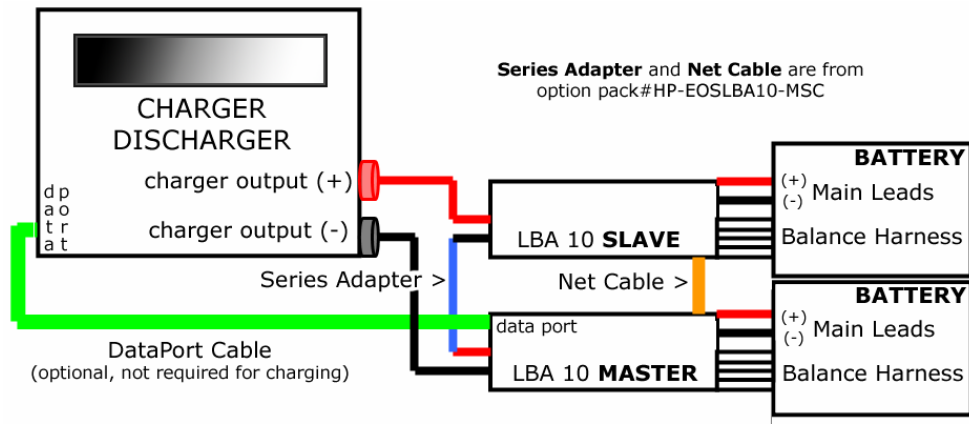

## Data Display

