

Instrument Messages and Functional Tests

Agilent Technologies

PSA Series Spectrum Analyzers

and

ESA Series Spectrum Analyzers



Agilent Technologies

Manufacturing Part Number: E4440-90267

Supersedes: E4440-90246

Printed in USA

November 2004

© Copyright 2001-2004 Agilent Technologies, Inc.

Notice

The information contained in this document is subject to change without notice.

Agilent Technologies makes no warranty of any kind with regard to this material, including but not limited to, the implied warranties of merchantability and fitness for a particular purpose. Agilent Technologies shall not be liable for errors contained herein or for incidental or consequential damages in connection with the furnishing, performance, or use of this material.

Where to Find the Latest Information

Documentation is updated periodically. For the latest information about Agilent PSA or ESA spectrum analyzers, including firmware upgrades and application information, please visit the following Internet URLs:

<http://www.agilent.com/find/esa>

<http://www.agilent.com/find/psa>

1. Instrument Messages	
Instrument Messages Introduction	28
Error Queues	29
Error Message Format	30
Error Message Types	31
Instrument Messages	32
Error Messages	32
Instrument Messages Without Numbers	84
2. Functional Tests	
What You Will Find in This Chapter	98
What Are the Functional Tests?	98
Functional Test Versus Performance Verification	98
This chapter includes the following:	98
Before Performing a Functional Test	100
Test Equipment	101
3. PSA Functional Tests	
Amplitude Accuracy at 50 MHz	106
Test Limits	106
Test Description	106
Procedure	107
Testing Option 1DS (Preamp)	110
Displayed Average Noise Level (DANL)	111
Test Limits (with 0 dB input attenuation)	111
Test Description	111
Procedure	111
Frequency Readout Accuracy	113
Test Limits	113
Test Description	113
Procedure	114
Frequency Response (Flatness)	115
Test Limits	115
Test Description	115
Procedure	116
Amplitude Linearity	119
Test Limits	119
Test Description	119
Procedure	120
Second Harmonic Distortion (SHD)	122
Test Limits	122
Test Description	122
Procedure	123
4. ESA Functional Tests	
Displayed Average Noise Level	126
Test Limits	126
Test Description	127

Contents

Procedure (10 MHz to 500 MHz) E4401B and E4411B	127
Procedure (501 MHz to 1.0 GHz) E4401B and E4411B	129
Procedure (1.01 GHz to 1.5 GHz) E4401B and E4411B	130
Procedure (10 MHz to 1 GHz) E4402B, E4403B, E4404B, E4405B, E4407B, E4408B ...	131
Procedure (1.01 GHz to 2 GHz) E4402B, E4403B, E4404B, E4405B, E4407B, E4408B ..	132
Procedure (2.01 GHz to 3.0 GHz) E4402B, E4403B, E4404B, E4405B, E4407B, E4408B ...	133
Procedure (3.01 GHz to 6.0 GHz) E4404B, E4405B, E4407B, and E4408B	134
Procedure (6.01 GHz to 6.7 GHz) E4404B	135
Procedure (6.01 GHz to 12.0 GHz) E4405B, E4407B, and E4408B	136
Procedure (12.01 GHz to 13.2 GHz) E4405B	137
Procedure (12.01 GHz to 22 GHz) E4407B and E4408B	138
Procedure (22.01 GHz to 26.5 GHz) E4407B and E4408B	139
Frequency Readout Accuracy	142
Test Limits	142
Test Description	142
Procedure	143
Marker Count Accuracy	145
Procedure	145
Frequency Response (Flatness)	146
Test Limits	146
Test Description	146
Procedure	147
Reference Level Accuracy	151
Test Limits	151
Test Description	151
Log Mode Procedure	152
Linear Mode Procedure	154
Resolution Bandwidth Switching Uncertainty	156
Test Limits	156
Test Description	156
Procedure	157
Scale Fidelity	159
Test Limits	159
Test Description	159
Procedure	160
Second Harmonic Spurious Responses	162
Test Limits	162
Test Description	162
Procedure	163
Tracking Generator Level Flatness: Models E4401B and E4411B, Options 1DN and 1DQ	165
Test Limits	165
Test Description	165
Procedure	166
Tracking Generator Level Flatness:	
E4402B, E4403B, E4404B, E4405B, E4407B and E4408B, Option 1DN	168
Test Limits	168
Test Description	168
Procedure	169

(ADC Align Failure)	89
(FM Demod Align Failure)	91
(IF Align Failure)	91
(IF/ADC Over Range)	91
(LO Align Failure) status bit only, no message	92
(RF Align Failure)	93
(TG Align Failure) status bit only, no message	94
* (Invalid Data)	89
*CLS	29
*CLS	32
<directoryname> directory deleted	84
<directoryname1> directory renamed to	84
<filename> file copied	84
<filename> file deleted	84
<filename> file loaded	84
<filename> file saved	84
<filename> too many data entries	85
<filename1> file renamed to	85
<name1> directory renamed to <name2>	84
<name1> file renamed to <name2>	85
'10101010' pattern not detected - results may be inaccurate.	63
100 spurs found. Additional spurs ignored	68
10537 Cancellation trace has different X-Scale to Smoothed trace.	71
1st LO Unlock; Failure acquiring FracN LO frequency lock	39
1st LO Unlock; Failure acquiring single loop FracN LO lock.	39
2nd LO Unlock	39
3 – 26.5 GHz preselector bypassed, can't adjust	43
–350, Queue overflow	29
4th LO Unlock.	40
50 MHz Osc Unlevel (50 MHz Osc Unleveled)	89
AC Coupled	43

Instrument Messages

Alphabetical Listing

Acquiring Data...	53
Actual Trig Delay = Remote Trig Delay + Remote Trig Offset	43
ADC overload -- Carrier not at expected frequency	73
Align Now All Needed (Align Needed)	89
Align Now RF Needed (Align Now RF Needed)	89
Align RF Skipped (Align RF Skipped)	89
Align RF Skipped, Align signal amplitude too low	90
Align	95
Alignment Failed	78
Allowable CF for current span exceeded.	52
Allowable span for current center frequency exceeded	52
Attempt to change signal data failed.	84
Atten auto set to 15 dB	85
Auto Align not available when using Calibration Defaults.	47
Auto ranging...	85
Average Type incompatible for scale.	43
Avg Mode changed to Exp for Examine Meas Type	68
Avg Mode changed to Exp for Examine Meas Type	69
Avg Mode changed to Repeat for Full Meas Type	68
Avg Mode changed to Repeat for Full Meas Type	69
Awaiting trigger	60
Awaiting Trigger, no AUTO Trig.	53
Awaiting valid signal.	84
B7D and/or B7E not found. Code Domain not available.	85
B7D and/or B7E not found. Mod Acc not available.	85
B7D DSP Code Fail. Reload Opt BAH. Contact your Service Center	56
B7D DSP Code Fail. Reload Opt BAH. Contact your Service Center.	55
B7D DSP Code Fail. Reload Opt. 202. Contact your Service Center	64
B7D DSP Code Fail. Reload Opt. 202. Contact your Service Center.	64
B7D DSP Code Install Fail Opt.229. Contact your Service Center.	66
B7D DSP Code Install Fail Opt.231. Contact your Service Center.	67

B7D DSP Code Reload Fail Opt.229. Contact your Service Center.	66
B7D DSP Code Reload Fail. Opt.231. Contact your Service Center.	68
Bad or missing floppy disk.	46
Bad or missing floppy disk.	51
Bad, missing, or unformatted disk.	46
Bad, missing, or unformatted disk.	51
Band Measurement not defined for Out of Band.	57
Block data error.	36
Block data not allowed.	36
Break freq > FFT filter edge.	73
Burst Delay out of limit for EVM (2 ms).	76
Burst Delay out of limit for EVM (2 ms).	76
Burst not found.	62
Burst not found.	75
Cal Data corrupt. Wideband cal failed. Using previous data.	66
Cal file not initialized correctly, <filename>.	52
Cal Oscillator Unlock.	40
Calibration failed.	33
Can not get long code phase (RS-232).	75
Can't Auto-Couple RBW in Zero Span.	46
Can't Auto-Couple Sweep Time in Zero Span.	41
Can't Auto-Couple Sweep Time in Zero Span.	46
Can't compute result - not enough transitions.	64
Cancellation disabled while measuring DANL Floor.	71
Cancellation trace is not set to Reference or has no data.	71
Cannot correlate to input signal.	60
Cannot correlate to input signal.	74
Cannot correlate to input signal.	75
Cannot correlate to input signal.	77
Cannot correlate to input signal.	81
Cannot display Ref Trace because it has no data.	70

Instrument Messages

Alphabetical Listing

Cannot find the Power vs Time Limits File.....	57
Cannot find the Power vs Time Limits File.....	59
Cannot load a directory	52
Cannot load a directory, please choose a file	52
Cannot locate the file that contains the list of cable types.....	58
Cannot lock to carrier.	67
Cannot open trace file for writing. Save Failed.....	70
Cannot save Ref Trace because it contains no data.	70
Cannot save Trace because it contains no data.....	70
Cannot sync DPCCH pilot.	75
Cannot synchronize frame trigger	72
Cannot synchronize to RF amplitude (burst error)	72
Cannot update the list of cable types on drive C:.....	58
Cannot update the list of cable types.....	57
Carrier frequency outside device's transmit band	73
Carrier Not Present	71
Carrier Not Present. Verify frequency and amplitude settings.....	71
Carrier Not Present.	57
Carrier Not Present.	58
Carrier Not Present.	67
Carrier Not Present.	85
Carrier power too low for optimum dynamic range	74
Carrier Present. Test Stopped!	58
Channel center frequency outside device's transmit band.....	76
Channel frequency outside device's transmit band.....	85
Character data error	37
Character data not allowed.....	37
Character data too long	37
CMD ERR, <name of offending command>	77
CMD NOT SUPPORTED, <command>	77
Command error	39

Command header error	38
Command not recognized	41
Command not supported	69
Command not valid in this mode.	78
Command not valid in this model	42
Command not valid when no measurement is active	42
Connect Amptd Ref Output to Input	47
Connect RF OUT to INPUT	47
Connection could not be established with specified IP Address.	83
Corrupt media.	34
Corrupted file	44
Corrupted file	46
Critical memory shortage occurred.....	75
Data corrupt or stale.	34
Data corrupt or stale; EEPROM copy of <file>	34
Data corrupt or stale; EEPROM copy of <file>	44
Data corrupt or stale; NRAM copy of <file>	34
Data corrupt or stale; RAM copy of <file>	44
Data out of range	34
Data questionable; EEPROM copy of <file>	45
Data type error	39
DC Coupled	90
Default spur table values loaded.	85
Demod Format setting does not allow this value for Points/Symbol.....	66
Demod ON: reduce span for audible detection	90
Device = Mobile. Code Domain not available.....	86
Device = Mobile. Mod Acc not available.	86
Device-specific error	33
Diagnostic override of Firmware Control; :DIAGnostic:ABUS	40
Diagnostic override of Firmware Control; :DIAGnostic:AMP	40
Diagnostic override of Firmware Control; :DIAGnostic:LATCh	40

Instrument Messages

Alphabetical Listing

Diagnostic override of Firmware Control; :DIAGnostic:MLATCh	40
Diagnostic override of Firmware Control; :DIAGnostic:REGister:VALue	40
Diagnostic override of Firmware Control; :DIAGnostic:SBUS	40
Diagnostic override of Firmware Control; :DIAGnostic:SBUS:DBD.	40
Diagnostic override of Firmware Control; :DIAGnostic:SIO:PARallel	40
Diagnostic override of Firmware Control; :DIAGnostic:SIO:SERial.	40
Did not find 4 signals > Peak Excursion.	68
Directory already exists.	40
Directory already exists.	86
Directory already exists.	86
doing Alignment...	53
DSP algorithm timeout, aborting measurement	56
DSP timed out, resetting DSP.	60
Dynamic range not optimum.	72
EDGE EVM only supports EDGE TCH burst type (Burst Type)	59
EDGE EVM only supports EDGE TCH burst type (Ref Burst)	59
EDGE ORFS only supports EDGE TCH burst type (Burst Type)	59
EDGE ORFS only supports EDGE TCH burst type (Ref Burst).	59
EDGE PVT only supports EDGE TCH burst type (Burst Type).	59
EDGE PVT only supports EDGE TCH burst type (Ref Burst)	59
EDGE Upgrade (252) unlicensed. Please contact your Agilent Sales Rep.	65
Emission bandwidth not found. Consider increasing span.	62
ENR table will be extrapolated.	86
Entire trace is below the threshold level.	86
Entire trace is below threshold level	57
Error reading file: CDMASTUN.CSV. Please reinstall cdmaOne.	61
Error reading file: CDPMDA. Please reinstall cdmaOne.	61
Error reading file: CDPPMCO. Please reinstall cdmaOne.	61
Error reading file: CDPPMDA. Please reinstall cdmaOne.	61
Error reading file: OOBSTAB.CSV. Use Edit Table Save Table.	62
Error reading file: RHODMDA. Please reinstall cdmaOne.	62

Error reading file: RHOPMCO. Please reinstall cdmaOne.	62
Error reading file: SPCLIMIT.CSV. Cannot use custom limits.	61
EVM Measurement only supports EDGE TCH burst type	74
Execution Error.	35
Exponent too large	37
Expression data error	36
Expression data not allowed	36
Ext Ref.	41
Ext Ref.	90
Ext Ref.	95
External LO frequency out of range	90
External mixing is off, can't adjust external preselector	43
External reference missing or out of range	47
Failed to Initialize ISTATE regions. Fatal LDS error.	51
Failed to load ENR data	80
Failed to load Frequency List.	80
Failed to load Limit line	80
Failed to load Loss data	80
Failed to Load trace. Bad file format.	70
Failed to store ENR data	80
Failed to store Frequency List	80
Failed to store Limit line	80
Failed to store Loss data.	80
Failed to store Trace	80
File access IO busy; duplicate :SERVICE[:PRODUCTION]:CALIBRATE:BEGIN.	46
File access IO busy; :SERVICE[:PRODUCTION]:CALIBRATE:END without a BEGIN.	46
File access is denied	45
File already exists.	44
File already exists.	46
File already exists.	79
File does not exist	79

Instrument Messages

Alphabetical Listing

File exists	44
File exists	46
File is corrupt	44
File is corrupt	46
File name error	44
File name error	45
File name error; Directory does not have a default file type	44
File name error; Directory does not have a default file type	45
File name error; Directory does not support extenders	44
File name error; Directory does not support extenders	45
File name error; Empty filename	44
File name error; Empty filename	45
File name error; Illegal extender	44
File name error; Illegal extender	45
File name error; Illegal filename character	44
File name error; Illegal filename character	45
File name error; Only one extender character allowed	44
File name error; Only one extender character allowed	45
File name error; Only one: is allowed	44
File name error; Only one: is allowed	45
File not found	43
File not found	46
File Operation Status; <name> directory deleted	40
File Operation Status; <name> directory renamed to <name>.	40
File Operation Status; <name> file copied	40
File Operation Status; <name> file deleted	41
File Operation Status; <name> file loaded	41
File Operation Status; <name> file renamed to <name>	41
File Operation Status; <name> file saved	41
File Operation Status; directory <name> created	40
File Operation Status; Volume <name> formatted	41

Final IF Overload (IF/ADC Overrange)	90
Final IF Overload	40
First harmonic is past analyzer frequency limit.	54
First IF Overload (IF/ADC Overrange)	90
Flash memory is full	46
Flat corr off (no corresponding status bit)	91
Floppy disk error.	43
Floppy disk full	43
Freq band crossing not supported by Option 215	83
Freq corr off (no corresponding status bit)	91
Freq Count: Reduce Span/RBW ratio	40
Freq Count: Reduce Span/RBW ratio	91
Freq outside cal range	91
Freq range of ext src exceeded, PSA setting adjustments required.	83
FreqRefUnlock	95
Frequency Hopping enabled, waiting for valid burst	80
Frequency Reference Error (Freq Ref Unlocked)	91
Gate option not installed. Results may not be accurate.	58
Gate option not installed. Results may not be accurate.	59
GET not allowed	38
GSM burst out of limits	72
GSM Hopping enabled, waiting for valid burst	72
GSM Pwr Meas requires trig delay < -50 μ s. Delay set to -50 μ s	73
GSM RF sync delay is out of range	72
Hardkeys are disabled.	60
Hardware missing.	34
Hardware missing; no such SIO address.	34
Hardware upgrade required. Option 215 disabled.	83
Header separator error.	38
Header suffix out of range	38
HW Average	86

Instrument Messages

Alphabetical Listing

HW Diag is OFF.	43
IF BW is clipped to its limit because of IF Path change.	82
IF Gain fixed	91
IF over range req. RF re-range: Meas Restarted.	79
IF Overload.	91
Illegal MSDOS name given	79
Illegal parameter value	34
Illegal write access of Flash memory	46
In <command>: bad data count (<numeric_value>): expected multiple of <numeric_value>.	48
In <filename>, line <nnn>: separator missing.	48
In <filename>, line <numeric_value>: <xxx> is not numeric	49
In <filename>, line <numeric_value>: error parsing tokens.	49
In <filename>, line <numeric_value>: line too long.	48
In <filename>: [DATA] header missing	48
In <filename>: bad amplitude unit <unit>.	49
In <filename>: error reading file.	48
Incorrect filename, allowable extension ENR	80
Incorrect filename, allowable extension is .sta.	51
Incorrect filename, allowable extension LOS.	80
Incorrect filename, allowable extension LST	80
Incorrect filename, allowable extension	79
Incorrect filename, allowable extensions are .gif or .wmf	51
Incorrect filename, allowable extensions are .gif or .wmf	51
Incorrect filename, allowable extensions are .trc or .csv	50
Incorrect filename, allowable extensions are .trc or .csv	51
Incorrect filename, allowable extensions LIM	80
Incorrect RBW for demod - change RBW	72
Incorrect trigger holdoff.	73
Input is internal (no corresponding status bit)	92
Input overload	74
Input overload	76

Input power too low	74
Input power too low	75
Input power too low	81
Instrument mode requested is not supported	52
Instrument state may be corrupt, state has been reset to initial values	49
Instrument state set to initial values	49
Insufficient pre-Trig for demod - decrease Trig Delay	72
Interpolation error: cannot compute log of <negative_frequency_value>	49
Invalid Baud Rate	42
Invalid block data	36
Invalid character data	37
Invalid character in number	38
Invalid character	39
Invalid EDGE burst timing	86
Invalid expression	36
Invalid format: CSV files are not supported by this measurement.	70
Invalid format: CSV files are not supported by this measurement.	86
Invalid frequency list for measurement mode	78
Invalid GSM burst timing	72
Invalid instrument mode	51
INVALID ITEM, <offending item>	77
Invalid Marker Trace. Marker moved to Raw Trace	70
Invalid option, unable to uninstall package	42
Invalid printer response	48
INVALID SAVE REG, <invalid register>	77
Invalid separator	39
Invalid State Register	69
Invalid string data	36
Invalid suffix	37
INVALID TRACE, <trace>	77
Level is low, results may degrade	61

Instrument Messages

Alphabetical Listing

LO – Stop freq must be \geq min system input freq.	92
LO Out Unlevel (LO Out Unleveled)	92
LO Unlevel (LO Unleveled)	92
LO Unlock (Synth Unlocked)	92
Log Corr Off (no corresponding status bit)	92
LOG FILE CLEARED	77
LOG FILE FULL, CLEAR FOR FURTHER ERROR LOGGING	77
Lost trigger, aborting measurement.	56
Lower Custom Mask is Invalid!	57
Lower Custom Mask is Invalid!	58
Marker Count:Widen Res BW	92
Marker Freq Count HW Failure	41
Marker X value not adjusted when right of Rise&Fall mark	73
Mask unavailable for current Span - increase to display mask.	59
Mass storage error; EEPROM write timeout on EEPROM.	34
Mass storage error; EEPROM write timeout	45
Meas Interval is clipped to its upper limit because of points/symbol change.	82
Meas Type changed to Examine for Exp Avg Mode	68
Meas Type changed to Examine for Exp Avg Mode	69
Meas Type changed to Full for Repeat Avg Mode	68
Meas Type changed to Full for Repeat Avg Mode	69
Meas Uncal (Oversweep)	92
Meas Uncal.	40
Measurement does not support the current radio standard.	59
Measurement failed for unknown reasons.	60
Measurement halted. Press a measurement key to continue.	87
Measurement not defined for Out of Band.	56
Measurement outside Internal Preamp range	92
Measurement partially outside Internal Preamp range	93
Measurement suspended until carrier is turned off.	60
Measurement uncalibrated, symbol rate exceeds $\pm 10\%$ nominal.	66

Measurement uncalibrated, wideband calibration required.....	65
Media is corrupt	45
Media is not writable	45
Media is not writable	47
Media is not writable	79
Media is protected.....	43
Media is protected.....	44
Media is protected.....	79
Memory limit caused Data Acquisition to be truncated.....	53
Missing parameter	38
Mode Setup Error	78
Neg. Trig Delay unavailable in Swept Mode, zero delay used.	42
No entries in ENR table	79
No entries in frequency list	78
No entries in Limit Line table	79
No entries in loss table	79
No error	32
No Fast ADC hardware installed.....	56
No Fast ADC hardware installed. Meas unavailable.....	87
No Fast ADC hardware installed.....	56
No Fast ADC hardware installed.....	57
No Fundamental > 0 Hz found in given span.	54
No Fundamental > -50 dBm found in given span.	54
No peak found	41
No Peak Found	52
No power at carrier frequency	77
No ranges are defined.....	69
No spurs have been found	69
No trigger before timeout; auto-triggered.....	53
Noise Figure DLP requires Noise Source Control Hardware.....	80
Not enough frequency range to measure harmonics for channel.....	87

Instrument Messages

Alphabetical Listing

Numeric data error	38
Numeric data error; VGR	38
Numeric data not allowed	37
...Averaging unavailable when Sig ID is on	34
...Cannot center unpreselected external mixer	34
...Command incompatible with band pair marker	34
...External mixing unavailable when preamp on	35
...FFT unavailable when Sig ID is on	35
One or more harmonics beyond freq limit: number decreased	87
One or more harmonics past freq limit: number decreased	54
Opt 106 demod hardware required. Meas unavailable	63
Opt 106 hardware required. Preamble sync unavailable	63
Opt 229 DSP algorithm code file requires upgrade	66
Opt 229 DSP algorithm coef. file requires upgrade	66
Opt 231 DSP algorithm code file requires upgrade	67
Opt 231 DSP algorithm coef. file requires upgrade	67
Opt 252 DSP algorithm code file requires upgrade	64
Opt 252 DSP algorithm coef. file requires upgrade	64
Opt AYX hardware required. Meas unavailable	55
Opt B7D bootrom requires upgrade	55
Opt B7E RF hardware required. RF Burst unavailable	63
Opt BAH DSP algorithm code file requires upgrade	55
Opt BAH DSP algorithm coef. file requires upgrade	56
Opt BAH DSP algorithm files failed to load, aborting measure	56
Opt BAH DSP algorithm files not installed. Meas unavailable. Contact your Service Center	55
Opt Freq Ref setting does not match external reference	61
Option activated	87
Option B7D or AYX FADC hardware required. Meas unavailable	63
Option not installed	41
Option not licensed	42
Options B7D & B7E hardware required. Meas unavailable	55

...Settings Conflict, Preamp unavailable in external mixing mode	35
...Sig ID requires EXTERNAL mixing mode	35
...Sig ID unavailable in Manual:FFT	35
...Sig ID unavailable when Averaging is on	35
...Sig ID unavailable when Signal Track is on	35
...Signal ID unavailable with Presel Mixer.	35
...Signal Track unavailable when Sig ID is on	35
Out of memory	33
Overload	95
Overload: Reduce Signal and press <ESC> (Input Overload Tripped)	93
PARAMETER ERROR, <name of offending parameter>	77
Parameter not allowed	38
Parameter unavailable in demod measurements..	63
Payload data pattern '10101010' not present..	63
Peaking Signal (no corresponding status bit)	93
Please set RF input range (INPUT menu) to manual first.	87
Points/Symbol changed to an even number because of demod format.	81
Preferred resolution bandwidth not available.	53
Preferred resolution bandwidth not available.	93
Preselector cannot be bypassed in this mode.	60
Preselector centering failed - inadequate peak.	43
Preselector centering failed	41
Preselector is not available at this frequency.	41
Preselector unavailable while in external mixing.	43
Pretrigger too long	74
Print failed; Can't open print file desc.	47
Print failed; DisplayExport can't create print file	47
Print failed; DisplayExport illegal print language	47
Print failed; DisplayExport insufficient RAM space.	47
Print failed; DisplayExport undetermined error	47
Print failed; Error transferring image to printer	47

Instrument Messages

Alphabetical Listing

Print failed; Printer ioctl failed.	47
Print failed; Unknown printer response.	47
Printer interface error	48
Printer not responding.	47
Printer not responding; ioctl ERROR	47
Printer out of paper	47
Printer Type is None	48
Program mnemonic too long	38
Query DEADLOCKED	32
Query Error	33
Query INTERRUPTED	32
Query UNTERMINATED after indefinite response	32
Query UNTERMINATED	32
Radio standard is not supported by the current measurement.	59
RBW limited to 1 kHz when Span > 5 MHz.	42
Requested timeslot number not present.	73
Require 4 Signals > PEAK EXCURSION above Threshold.	68
Required Input attenuation not calibrated	78
Required payload data pattern '10101010' not present.	64
Required payload data pattern '11110000' not present.	64
Resolution BW < 300kHz.	59
Resolution BW <300 kHz.	57
Restoration of NVRAM data	45
Restoration of NVRAM data"	47
RF Board could not detect any bursts in signal.	61
RF Board LO Unlocked. Contact service center.	61
RF Board RF Osc Unlocked. Contact service center.	61
RF Board SR Osc Unlocked. Contact service center.	61
RF re-range required: Meas Restarted.	79
RF Signal not found.	61
RS-232 Interface Error	42

Sample Clock Unlock	40
Sampling Oscillator Unlock; Failure acquiring SO frequency lock	39
SCPI marker query not available in GSM Rise&Fall	73
Search Length is clipped to the lower value as allowed by current IF Band Width.	82
Search Length is clipped to the upper value according the dependency of IF Band Width	82
Select a valid Radio Standard/Measurement combination to enable.	59
Self-test failed; EEPROM checksum for	33
Settings conflict; parameter currently disabled	35
Settings conflict;.	34
Shutdown in process.	87
Signal exceeds maximum allowable power	76
Signal Ident On, Amptd Uncal (Signal Ident On).	93
Signal level is low.	93
Signal too noisy	73
Signal too noisy	74
Signal too noisy	75
Signal too noisy	76
Signal too noisy	76
Signal too noisy	81
Signal Tracking disabled when measuring DANL Floor (Removal).	71
Signal Tracking is not available when Noise Correction is on.	54
Signals to not fit expected Intermod (TOI) pattern	68
Source LO Unlock (Source Synth Unlocked).	93
Source Unlevel (Source Unleveled)	94
Span limited to 5 MHz when RBW < 1 kHz	42
Start – LO freq must be >= min system input freq.	94
Start freq must be greater than fixed LO freq	94
Start freq must be greater than start RF freq	94
Start Marker must be at least 1% < Stop Marker.	63
Stop freq must be less than fixed LO freq.	94
Stop freq must be less than stop RF freq	94

Instrument Messages

Alphabetical Listing

Stop IF freq must be less than fixed LO freq94
Stop Marker must be at least 1% > Start Marker.63
Store Ref trace before turning on Normalize52
String data error36
String data not allowed36
Suffix error37
Suffix not allowed.37
Suffix too long.37
Sweep Point/Span ratio below minimum - results may be inaccurate.59
Sweep Time too fast (<2 sec)58
Symbol Rate is clipped to its limit because of IF Path change.82
Sync is RF Ampl (not Training Seq). Bits not accurate73
Sync offset value not valid.82
Sync Pattern includes non-hex characters82
Sync Word Length changed to new upper limit82
Sync word not found in frame (Burst Type)54
Sync word not found in frame (Burst Type)73
Sync word not found in frame (Ref Burst)55
Sync word not found in frame (Ref Burst)73
Sync word not found in frame (TSC).65
Sync word not found in specified timeslot (Burst Type)55
Sync word not found in specified timeslot (Burst Type)73
Sync word not found in specified timeslot (TSC)..65
Sync word not found71
Sync word not found72
Sync word not found76
Sync word not found76
Sync word not found81
Syntax error39
System Alignments, Align Now, All Required94
System error.33

System error; Pretune DAC Cal failed midpoint verification	33
System error; Pretune DAC Calibration failed.	33
System input frequency out of range.	94
System, Alignments, Align All Now Needed (Align Needed)	94
System, Alignments, Align All Now, Needed.	39
SYSTem:ERRor?	29
T hot must be greater than T cold	79
Table could not be loaded.	62
Table could not be saved.	62
Table loaded successfully.	87
Table saved successfully.	87
TG Frequency Limit	41
TG start freq is less than 1/2 res bw	42
TG start freq is less than 9 kHz.	42
The Cable Fault Measurement is active. Mode Setup is disabled.	58
The calibration data is invalid, and has been cleared.	56
The calibration data is invalid, and has been cleared.	87
The file containing the list of cable types has been updated.	58
The file containing the list of cable types has been updated.	88
The regression portion failed.	60
There are no spurs to inspect.	58
There is no valid result to hold.	64
This measurement does not support the *.CSV file format.	69
This measurement does not support the *.CSV file format.	88
This operation requires a measurement to be active.	56
This operation requires a measurement to be active.	66
This operation requires a measurement to be active.	88
Time resolution is low, reduce Meas Time or increase Trace Points	88
Too many data values at <freq_or_time_value>	49
Too many digits.	37
Too much data; not all points entered	34

Instrument Messages

Alphabetical Listing

Trace file contains no compatible traces.	70
Trace file saved successfully.	70
Trace file was created by incompatible version of Opt. 226.	70
Trace Menu is unavailable when Sig Ident is ON	42
Trace smoothing: VBW filt or Average Detector; cannot use both	43
Tracking Generator hardware is not present. Meas unavailable..	56
Tracking Peak Needed.	88
Trigger Offset unavailable in swept spans.	42
Two entries already exist at frequency.	78
Tx Band Spur measurement does not support this frequency band.	74
Tx Band Spur measurement not defined for mobiles	73
Unable to Calculate Result using Current Setup.	63
Unable to demodulate signal.	74
Unable to format drive.	51
Unable to initialize flatness data	41
Unable to load file	50
Unable to load file	51
Unable to load state from file	49
Unable to load state from register	50
Unable to load state saved from firmware Rev A.xx.xx; Restore Sys \nDefaults.	50
Unable to load state	50
Unable to load user state, factory preset was done	50
Unable to load user state, required instrument mode is not installed	51
Unable to query state.	50
Unable to retrieve signal (remote).	84
Unable to save file	51
Unable to save file, invalid path	40
Unable to save state to file	50
Unable to save state to register.	50
Unable to save user state	50
Unable to set state	50

Unable to store flatness data	41
Unable to store reference trace.	83
Unable to uninstall personality, file not deletable.	84
Uncal	95
Undefined header	38
Unexpected carrier frequency (BMT only)	74
Unknown demod status	55
Unknown printer	48
Unlevel	95
Unlock	96
Unpreselected external mixing - no preselector	43
Unsupported printer.	48
Upper Custom Mask is Invalid!	57
Upper Custom Mask is Invalid!	58
Use trigger delay to align bit p0 center on marker.	88
Use View/Trace menu when loading or saving logarithmic traces.	70
User cal invalidated	78
Valid 1xEV burst not found	81
Valid Bluetooth burst not found. (Check Packet Type).	62
Valid burst not found in frame (Burst Type).	65
Valid burst not found in specified timeslot (Burst Type).	65
Valid burst not found	57
Valid burst not found	68
Valid burst not found	81
Valid burst not found.	67
Valid EDGE burst not found in frame (Burst Type).	64
Valid EDGE burst not found in frame (Ref Burst)	64
Valid EDGE burst not found in specified timeslot (Burst Type)	64
Valid GSM burst not found for selected timeslot	74
Valid GSM burst not found in frame (Burst Type)	54
Valid GSM burst not found in frame (Burst Type).	72

Instrument Messages

Alphabetical Listing

Valid GSM burst not found in frame (Ref Burst)	54
Valid GSM burst not found in frame (Ref Burst).	72
Valid GSM burst not found in specified timeslot (Burst Type)	54
Valid GSM burst not found in specified timeslot (Burst Type).	72
Valid GSM burst not found	72
Valid NADC burst not found	76
Valid PDC burst not found	76
Valid PRACH burst not found.	75
Valid signal not found	81
Valid signal not found.	65
Video bandwidth fixed at 50MHz by Option 215	83
Video shift off (no corresponding status bit).	95
Video Trigger cannot be active with Average Detector	52
Video Trigger cannot be used with Mkr Func due to Average Detector	52
Volume <name> formatted	88
Waiting for end of data acquisition to access floppy disk	88
WARNING: You are about to delete all of the contents of directory "x:\xxxxx\". Press Delete Now again to proceed or any other key to abort.	88
WARNING: You are about to delete all of the contents of directory xxxxxx. Press Delete Now again to proceed or any other key to abort.	88
WBIF ADC Image Calibration Failed	53
WBIF Firmware Reset.	53
WBIF Power On Test Failed	53
WBIF Self Test Failed	52
Wideband calibration not valid until Align Now, All performed.	65
Wrong density floppy inserted	46

1 Instrument Messages

Instrument Messages Introduction

The analyzer can generate various messages that appear on the display during operation. There are four types of messages.

This chapter describes the following types of messages displayed on the analyzer:

- | | |
|--|--|
| User Error Messages | Beginning on page 32 , User Error Messages appear when an attempt has been made to set a parameter incorrectly or an operation has failed (such as saving a file). These messages are often generated during remote operation when an invalid programming command has been entered. These messages appear in the status line at the bottom of the display. If you are using the default display colors, the message will appear in yellow. The message will remain until you preset the analyzer, press ESC , or another message is displayed on the status line. |
| Informational Messages | Beginning on page 84 , Informational Messages provide information that requires intervention. These messages appear on the status line at the bottom of the display. If you are using the default display colors, the message will appear in green (ESA) or yellow (PSA). The message will remain until you preset the analyzer, press ESC , or another message is displayed on the status line. The information provided in brackets, for example <filename> or <directory>, is a variable that represents a specific input provided previously. |
| Status Messages | Beginning on page 89 , Status Messages appear on the right side of the analyzer display and/or set status bits in the SCPI Status Register system. These messages indicate a condition that may result in erroneous data being displayed. Most messages will only be displayed until the error condition is corrected. Multiple messages can be displayed and will be listed in the display area. In each case the name of the corresponding status bit is indicated in parenthesis. It will be noted if only a status bit is used (no message). |
| Pop-up Messages | These messages indicate a condition that may require intervention. They appear in the middle of the display in a framed box. The message will remain until the appropriate intervention has taken place or the condition has been corrected. |

Error Queues

There are two types of error queues, front panel and remote interface. These two queues are viewed and managed separately. Refer to [Table 1-1](#), for more information on the characteristics of the Error Queue.

Front panel A summary of the last 11 error messages preceded by an error number may be viewed in the Error Queue by pressing, **System** then **Show Errors**. When a remote interface initiates activity that generates an error, the messages are output to the remote bus. When output to the remote interface, they are preceded by an error number.

Remote interface (SCPI) When a user error condition occurs in the analyzer as a result of SCPI (remote interface) activity, it is reported to both the front panel display error queue and the SCPI error queue. If it is a result of front panel activity, it reports to the front panel display error queue, and depending on the error, may also report to the SCPI error queue.

Table 1-1. Characteristics of the Error Queue

Characteristic	Front-Panel Display Error Queue	SCPI Remote Interface Error Queue
Capacity (number of errors)	11	30
Overflow Handling	Circular (rotating). Drops oldest error as new error comes in.	Linear, first-in/first-out. Replaces newest error with: -350, Queue overflow
Viewing Entries	Press: System, Show Errors ^a	Use SCPI query SYSTem:ERRor?
Clearing the Queue	Press: System, Show Errors, Clear Error Queue	Power up. Send a *CLS command. Read last item in the queue.

a. Error history includes the date and time an error last occurred, the error number, the error message, and the number of times the error occurred.

Error Message Format

The system-defined error numbers are chosen on an enumerated (“1 of N”) basis. The error messages are listed in numerical order according to the error message number. Status and Informational messages without numbers will be listed in alphabetical order following the numerical listing.

In this chapter, an explanation is included with each error to further clarify its meaning. The last error described in each class (for example, -400, -300, -200, -100) is a “generic” error. There are also references to the IEEE Standard 488.2-1992, *IEEE Standard Codes, Formats, Protocols and Common Commands for Use with ANSI / IEEE Std 488.1-1987*. New York, NY, 1992.

Error messages are displayed at the bottom of the screen in the status line. If you are using the default display colors, the message will appear in yellow. The error number is available through the remote interface and the show errors screen; it is not displayed in the status line.

Figure 1-1. Error Message Example

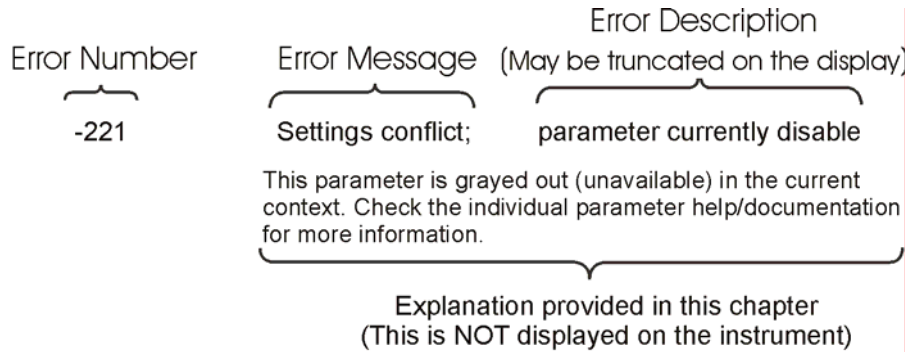

pk716b

Error Message Types

Events do not generate more than one type of error. For example, an event that generates a query error will not generate a device-specific, execution, or command error.

–499 to –400: Query Errors

These errors indicate that the analyzer output queue control has detected a problem with the message exchange protocol described in IEEE 488.2, Chapter 6. Errors in this class set the query error bit (bit 2) in the event status register (IEEE 488.2, section 11.5.1). These errors correspond to message exchange protocol errors described in IEEE 488.2, 6.5. In this case:

- Either an attempt is being made to read data from the output queue when no output is either present or pending, or
- Data in the output queue has been lost.

–399 to –300: Device-Specific Errors

An error number in the range –399 to –300 indicates that the analyzer has detected an error where some device operations did not properly complete, possibly due to an abnormal hardware or firmware condition. This is not a error in response to a SCPI query or command, or command execution. The occurrence of any error in this class will cause the device-specific error bit (bit 3) in the event status register to be set.

–299 to –200: Execution Errors

These errors indicate that an error has been detected during analyzer execution.

–199 to –100: Command Errors

These errors indicate that the analyzer parser detected an IEEE 488.2 syntax error. Errors in this class set the command error bit (bit 5) in the event status register (IEEE 488.2, section 11.5.1). In this case:

- Either an IEEE 488.2 syntax error has been detected by the parser (a control-to-device message was received that is in violation of the IEEE 488.2 standard. Possible violations include a data element which violates device listening formats or whose type is unacceptable to the device.), or
- An unrecognized header was received. These include incorrect device-specific headers and incorrect or unimplemented IEEE 488.2 common commands.

64 to 799: Device-Specific Errors

These errors indicate that a device operation did not properly complete, possibly due to an abnormal hardware or firmware condition. These codes are also used for self-test response errors. Errors in this class set the device-specific error bit (bit 3) in the event status register (IEEE 488.2, section 11.5.1).

The <error_message> string for a positive error is not part of the SCPI standard. A positive error indicates that the analyzer detected an error within the GPIB system, within the analyzer firmware or hardware, during the transfer of block data, or during calibration.

Greater than 10000: Measurement Applications Errors

These errors indicate that an error has been detected while executing measurements requiring a personality option such as the GSM Measurement Personality or those measurements found under the **MEASURE** front-panel key in SA mode.

Instrument Messages

Error Messages

NOTE Error numbers are displayed in the error queue, *not* on the display.
To see an error *number*, press **System, Show Errors**.

0: No Error

0 No error
The queue is empty. Either every error in the queue has been read, or the queue was cleared by power-on or *CLS.

-499 to -400: Query Errors

NOTE Error numbers are displayed in the error queue, *not* on the display.
To see an error *number*, press **System, Show Errors**.

-440 Query UNTERMINATED after indefinite response
Indicates that a query was received in the same program message after a query requesting an indefinite response was executed (see IEEE 488.2, 6.3.7.5).

-430 Query DEADLOCKED
Indicates that a condition causing a DEADLOCKED query error occurred (see IEEE 488.2, 6.3.1.7). For example, both the input buffer and the output buffer are full and the analyzer cannot continue. The analyzer automatically discards output to correct the deadlock.

-420 Query UNTERMINATED
Indicates that a condition causing an UNTERMINATED query error occurred (see IEEE 488.2, 6.3.2.2). For example, the device was addressed to talk and an incomplete program message was received.

-410 Query INTERRUPTED
Indicates that a condition causing an INTERRUPTED query error occurred (see IEEE 488.2, 6.3.2.7). For example, a query was followed by DAB or GET before a response was completely sent.

-400 Query Error
This is a generic query error for devices that cannot detect more specific errors. The code indicates only that a query error as defined in IEEE 488.2, 11.5.1.1.7 and 6.3 has occurred.

-399 to -300: Device-Specific Errors

NOTE Error numbers are displayed in the error queue, *not* on the display.
To see an error *number*, press **System, Show Errors**.

-340 Calibration failed
The instrument requires an **Align All Now**. Restore the alignment by pressing **System, Alignments, Align All Now**.

-330 Self-test failed; EEPROM checksum for <card>
The card identification header for a hardware card is incorrect. If the card is not properly identified, the instrument is likely to be non-functional. Report this error to the nearest Agilent Technologies sales or service office.

-321 Out of memory
An internal operation needed more memory than was available. Report this error to the nearest Agilent Technologies sales or service office.

-310 System error; Pretune DAC Calibration failed
System error; Pretune DAC Cal failed midpoint verification
System error
An internal system problem was detected. Report this error to the nearest Agilent Technologies sales or service office.

-300 Device-specific error
This is a generic device-dependent error for devices that cannot detect more specific errors. The code indicates only that a device-dependent error as defined in IEEE 488.2, 11.5.1.1.6 has occurred. Report this error to the nearest Agilent Technologies sales or service office.

-299 to -200: Execution Errors

NOTE Error numbers are displayed in the error queue, *not* on the display.
To see an error *number*, press **System, Show Errors**.

- 253 Corrupt media
A removable media was found to be bad or incorrectly formatted. Any existing data on the media may have been lost.
- 250 Mass storage error; EEPROM write timeout on EEPROM
Failure to initialize EEPROM. Report this error to the nearest Agilent Technologies sales or service office.
- 241 Hardware missing
Hardware missing; no such SIO address
Missing device hardware. For example, an option is not installed.
- 230 Data corrupt or stale
Data corrupt or stale; EEPROM copy of <file>
Data corrupt or stale; NRAM copy of <file>
Possibly invalid data. A new measurement was started but not completed.
- 224 Illegal parameter value
You have sent a parameter for this command that is not allowed. See the Function Reference.
- 223 Too much data; not all points entered
Too much data; <description of the type of data exceeded>
Indicates that a legal program data element of block, expression, or string type was received that contained more data than the device could handle due to memory or related device-specific requirements.
- 222 Data out of range
A legal program data element was parsed but could not be executed because the interpreted value was outside the legal range defined by the device (see IEEE 488.2 11.5.1.1.5). The displayed results may be clipped.
- 221 Settings conflict;...
...Averaging unavailable when Sig ID is on
When in external mixing, with signal identification on, Averaging Mode is not available as a selection.
...Cannot center unpreselected external mixer
Mixer type is Unpreselected. Preselector centering is not available for unpreselected mixers.
...Command incompatible with band pair marker
Using remote commands, you have tried to adjust the start or stop frequency of a span pair marker. You can adjust only the center and span.

...External mixing unavailable when preamp on

Internal preamp is on and you tried to select external mixing, which is not available.

...FFT unavailable when Sig ID is on

When in external mixing, with signal identification on, the Manual FFT function is not available as a selection

...Settings Conflict, Preamp unavailable in external mixing mode

With external mixing selected, you cannot use the internal preamp.

...Sig ID requires EXTERNAL mixing mode

The Input Mixer setting is set in internal and you tried to select signal identification which is not valid.

...Sig ID unavailable in Manual:FFT

When in external mixing, with FFT on, signal identification is not available as a selection.

...Sig ID unavailable when Averaging is on

When in external mixing, with Averaging Mode on, signal identification is not available as a selection.

...Sig ID unavailable when Signal Track is on

When in external mixing with signal tracking on, signal identification is not available as a selection.

...Signal ID unavailable with Presel Mixer

Signal identification is not available with the preselected mixer selected.

...Signal Track unavailable when Sig ID is on

Signal tracking is not available as a selection when using external mixing with signal identification on.

Settings conflict; parameter currently disabled

This parameter is grayed out (unavailable) in the current context. Check the individual parameter help/documentation for more information.

-200

Execution Error

For devices that cannot detect more specific errors, this code indicates only that an execution error as defined in IEEE 488.2, 11.5.1.1.5 has occurred.

-199 to -100: Command Errors

NOTE Error numbers are displayed in the error queue, *not* on the display.
To see an error *number*, press **System, Show Errors**.

- 178 Expression data not allowed
A legal expression data was encountered, but was not allowed by the device at this point in parsing.
- 171 Invalid expression
The expression data element was invalid (see IEEE 488.2, 7.7.7.2). For example, unmatched parentheses or an illegal character.
- 170 Expression data error
This error, as well as errors -171 through -179, is generated when parsing an expression data element. This particular error message is used if the device cannot detect a more specific error.
- 168 Block data not allowed
A legal block data element was encountered, but not allowed by the device at this point in the parsing.
- 161 Invalid block data
A block data element was expected, but was invalid (see IEEE 488.2, 7.7.6.2). For example, an END message was received before the end length was satisfied.
- 160 Block data error
This error, as well as errors -161 through -169, is generated when parsing a block data element. This particular error message is used if the device cannot detect a more specific error.
- 158 String data not allowed
A string data element was encountered, but not allowed by the device at this point in the parsing.
- 151 Invalid string data
A string data element was expected, but was invalid (see IEEE 488.2, 7.7.5.2). For example, an END message was received before the terminal quote character.
- 150 String data error
This error, as well as errors -151 through -159, is generated when parsing a string data element. This particular error message is used if the device cannot detect a more specific error.

- 148 Character data not allowed
A legal character data element was encountered where prohibited by the device.
- 144 Character data too long
The character data element contains more than twelve characters (see IEEE 488.2, 7.7.1.4).
- 141 Invalid character data
Either the character data element contains an invalid character or the particular element received is not valid for the header.
- 140 Character data error
This error, as well as errors -141 through -149, is generated when parsing a character data element. This particular error message is used if the device cannot detect a more specific error.
- 138 Suffix not allowed
A suffix was encountered after a numeric element which does not allow suffixes.
- 134 Suffix too long
The suffix contained more than twelve characters (see IEEE 488.2, 7.7.3.4).
- 131 Invalid suffix
Attempt to send a SCPI command with a suffix that does not match the current units for the function.
The suffix does not follow the syntax described in IEEE 488.2, 7.7.3.2, or the suffix is inappropriate for this device.
- 130 Suffix error
This error, as well as errors -131 through -139, is generated when parsing a suffix. This particular error message is used if the device cannot detect a more specific error.
- 128 Numeric data not allowed
A legal numeric data element was received, but the device does not accept one in this position for the header.
- 124 Too many digits
The mantissa of a decimal-numeric data element contained more than 255 digits excluding leading zeros (see IEEE 488.2, 7.7.2.4.1).
- 123 Exponent too large
The magnitude of an exponent was greater than 32000 (see IEEE 488.2, 7.7.2.4.1).

- 121 Invalid character in number
An invalid character for the data type being parsed was encountered. For example, an alpha in a decimal numeric or a “9” in octal data.
- 120 Numeric data error; VGR
Numeric data error
This error, and errors -121 through -129, is generated when parsing a data element that appears to be numeric, including non-decimal numeric types. This message is used if the device cannot detect a more specific error.
- 114 Header suffix out of range
The value of a header suffix attached to a program mnemonic makes the header invalid.
- 113 Undefined header
The header is syntactically correct, but it is undefined for this specific device. For example, *XYZ is not defined for any device.
- 112 Program mnemonic too long
The header contains more than twelve characters (see IEEE 488.2, 7.6.1.4.1).
- 111 Header separator error
A character which is not a legal header separator was encountered while parsing the header.
- 110 Command header error
An error was detected in the header. This message is used when the device cannot detect the more specific errors described for errors -111 through -119.
- 109 Missing parameter
Fewer parameters were received than required for the header. For example, the *ESE common command requires one parameter, so receiving *ESE is not allowed.
- 108 Parameter not allowed
More parameters were received than expected for the header. For example, the *ESE common command only accepts one parameter, so receiving *ESE 0,1 is not allowed.
- 105 GET not allowed
A Group Execute Trigger was received within a program message (see IEEE 488.2, 7.7). Correct the GPIB controller program so that the GET does not occur within a line of GPIB program code.

- 104 Data type error
The parser recognized a data element that is not allowed. For example, numeric or string data was expected, but block data was encountered.
- 103 Invalid separator
The parser was expecting a separator and encountered an illegal character. For example, the semicolon was omitted after a program message unit.
- 102 Syntax error
An unrecognized command or data type was encountered. For example, a string was received when the device does not accept strings.
- 101 Invalid character
A syntactic command contains a character which is invalid for that type. For example, a header containing an ampersand, such as “SETUP&”. This error might be used in place of error numbers -114, -121, -141, and some others.
- 100 Command error
This is a generic syntax error for devices that cannot detect more specific errors. The code indicates only that a command error as defined in IEEE 488.2, 11.5.1.1.4 has occurred.

64 to 799: Device-Specific Errors

- 64 System, Alignments, Align All Now, Needed
- 102 There is too much 50 MHz energy at the RF port for alignments to run. Reduce input power and run alignments again.
- 103 Sampling Oscillator Unlock; Failure acquiring SO frequency lock
Report this error to the nearest Agilent Technologies sales or service office.
- 104 1st LO Unlock; Failure acquiring FracN LO frequency lock
1st LO Unlock; Failure acquiring single loop FracN LO lock
The first LO on has lost phase lock. Report this error to the nearest Agilent Technologies sales or service office.
- 105 2nd LO Unlock
The second LO has lost phase lock. Report this error to the nearest Agilent Technologies sales or service office.

- 106 4th LO Unlock
The fourth LO has lost phase lock. Report this error to the nearest Agilent Technologies sales or service office.
- 107 Sample Clock Unlock
Report this error to the nearest Agilent Technologies sales or service office.
- 108 Cal Oscillator Unlock
Report this error to the nearest Agilent Technologies sales or service office.
- 129 Meas Uncal
The measurement is uncalibrated, usually due to sweeping a narrow RBW filter too quickly. Check the sweep time, span, and bandwidth settings, or press **Auto Couple**.
- 143 Final IF Overload
Either increase input attenuation or decrease the input signal level.
- 163 Freq Count: Reduce Span/RBW ratio
The span is too wide for the current resolution bandwidth. Either reduce the span or increase the RBW.
- 177 Diagnostic override of Firmware Control; :DIAGnostic:ABUS
Diagnostic override of Firmware Control; :DIAGnostic:AMP
Diagnostic override of Firmware Control; :DIAGnostic:LATCh
Diagnostic override of Firmware Control; :DIAGnostic:MLATCh
Diagnostic override of Firmware Control; :DIAGnostic:REGister:VALue
Diagnostic override of Firmware Control; :DIAGnostic:SBUS
Diagnostic override of Firmware Control; :DIAGnostic:SBUS:DBD
Diagnostic override of Firmware Control; :DIAGnostic:SIO:PARAllel
Diagnostic override of Firmware Control; :DIAGnostic:SIO:SERial
- 187 Directory already exists
- 190 Unable to save file, invalid path
- 191 File Operation Status; directory <name> created
File Operation Status; <name> directory deleted
File Operation Status; <name> directory renamed to <name>
File Operation Status; <name> file copied

	File Operation Status; <name> file deleted
	File Operation Status; <name> file loaded
	File Operation Status; <name> file renamed to <name>
	File Operation Status; <name> file saved
	File Operation Status; Volume <name> formatted
196	Can't Auto-Couple Sweep Time in Zero Span
197	Marker Freq Count HW Failure
201	Option not installed
	The desired operation cannot be performed because a required option is not installed. For example, pressing Source with no tracking generator installed in the analyzer will generate this error.
202	No peak found
	No signal peak was found that meets the criteria under Peak Search, Search Param Criteria .
204	TG Frequency Limit
	The tracking generator has reached the limit of its allowable frequency range.
205	Ext Ref
205	Command not recognized
	Indicates that the command sent from the remote interface was not recognized. Check the programming guide for correct syntax.
206	Unable to initialize flatness data
	A failure occurred in setting the flatness data in the internal EEROM. Get in touch with your local Agilent Technologies sales and service office.
207	Unable to store flatness data
	A failure occurred in setting the flatness data in the internal EEROM. Get in touch with your local Agilent Technologies sales and service office.
208	Preselector is not available at this frequency.
	A preselector is available, but the marker is at a frequency which does not support preselection (~<3 GHz). Preselector centering can be performed only for frequencies above 3.025 GHz.
209	Preselector centering failed
	An attempt to center the preselector failed. You tried to center the preselector with the analyzer span too wide. Preselector centering can be performed only for spans below 1.123 GHz.

- 211 RBW limited to 1 kHz when Span > 5 MHz
In spans greater than 5 MHz, narrow (digital) resolution bandwidths, below 1 kHz, are not available.
- 213 Span limited to 5 MHz when RBW < 1 kHz
In narrow (digital) resolution bandwidths, below 1 kHz, spans greater than 5 MHz are not available.
- 214 TG start freq is less than 9 kHz
Tracking generator uncalibrated below 9 kHz.
- 215 TG start freq is less than 1/2 res bw
Tracking generator uncalibrated at start frequencies below 1/2 the current resolution bandwidth.
- 216 Invalid Baud Rate
Attempt to use invalid baud rate. Refer to the programming language chapter of *Agilent Technologies ESA Series Spectrum Analyzer Programmer's Guide* for more information.
- 217 RS-232 Interface Error
An error occurred on the serial interface.
- 219 Command not valid in this model
Indicates that the command sent from the remote interface does not apply to this analyzer model number. For example, attempting to center the preselector in an analyzer without a preselector will generate this error.
- 220 Trace Menu is unavailable when Sig Ident is ON
- 221 Invalid option, unable to uninstall package
You have attempted to remove a personality that is not currently installed. Verify command was entered correctly.
- 222 Command not valid when no measurement is active
Indicates that the command sent from the remote interface must be issued while a measurement is running in the analyzer.
- 223 Neg. Trig Delay unavailable in Swept Mode, zero delay used.
Trigger Offset unavailable in swept spans
Trigger Offset is only available in Zero Span. Refer to "Trig" in your *Agilent Spectrum Analyzer User's Guide* for a description of this function.
- 224 Option not licensed.
The selected option requires a license. Refer to the installation procedures in the user guide provided for this particular option.

- 226 Actual Trig Delay = Remote Trig Delay + Remote Trig Offset
- 228 Preselector centering failed - inadequate peak
The signal on which the marker is placed is not a high enough level peak for centering the preselector. This can be the result of pressing **Presel Center** without first turning off the marker. You may have left the marker on and placed below the signal peak or in the noise.
- 229 3 - 26.5 GHz preselector bypassed, can't adjust
The microwave preselector has been bypassed so it cannot be centered or adjusted. Pressing the key or send the SCPI commands for **Presel Center** or **Presel Adjust** will result in this error.
- 230 Unpreselected external mixing - no preselector
If you are using an unpreselected mixer while doing external mixing then there is no preselector to center or adjust. Pressing the key or sending the SCPI commands for **Presel Center** or **Presel Adjust** will result in this error.
- 231 Preselector unavailable while in external mixing
The internal preselectors cannot be used while in external mixing.
- 232 External mixing is off, can't adjust external preselector
External mixing is turned off so the external mixer preselector is not available.
- 238 Trace smoothing: VBW filt or Average Detector; cannot use both
- 239 HW Diag is OFF
- 249 AC Coupled
- 332 Average Type incompatible for scale.
Amplitude Scale command should be sent prior to the Average Type command.
- 601 PSA only
612 ESA only File not found
The analyzer could not find the specified file.
- 601 Floppy disk full
The floppy disk is full. Clear some space by deleting unwanted files.
- 602 PSA only
605 ESA only Media is protected
A save was attempted to a write-protected device.
- 602 Floppy disk error
An unknown error has occurred while accessing the floppy disk.

603 PSA only

615 ESA only File is corrupt

Corrupted file

The file that you were trying to load is corrupt.

604 PSA only

607 ESA only File name error

File name error; Directory does not have a default file type

File name error; Directory does not support extenders

File name error; Empty filename

File name error; Illegal extender

File name error; Illegal filename character

File name error; Only one: is allowed

File name error; Only one extender character allowed

An invalid file name was specified. Use filenames with a maximum of 8 characters (letters and digits only), and use a 3-character extension. File names are not case-sensitive. This error also occurs if you try to delete a nonexistent file.

615 PSA only

604 ESA only File exists

File already exists

You attempted to save to a file that already exists. Either delete or rename the existing file or select a new name, then try again.

602 PSA only

605 ESA only Media is protected

A save was attempted to a write-protected device.

605

Data corrupt or stale; EEPROM copy of <file>

WARNING: Contact the factory if you see this error.

This error indicates that a file stored in EEPROM has become corrupt and the Hamming codes are unable to repair the data.

When the EEPROM file has been corrupted, the system will store default values into both the Non-Volatile RAM and EEPROM copies of the file. If this error occurs often, it may indicate that there is a problem with the physical memory.

Data corrupt or stale; RAM copy of <file>

This error indicates that a file stored in Non-Volatile RAM has become corrupt and the Hamming codes are unable to repair the data.

When a Non-Volatile file has this error, the system will first try to verify

the state of the data in EEPROM and if valid it will copy the data in EEPROM into the Non-Volatile ram copy of the file. When this happens, the system will remain calibrated. If this error occurs often, it may indicate that there is a problem with the physical memory.

- 606 Data questionable; EEPROM copy of <file>
- EEPROM error occurred. The EEPROM copy of an internal file is either corrupt or otherwise unusable. The system automatically updates the non-volatile RAM copy of the EEPROM copy using a default initialization. The actual EEPROM file is left as it is. Report this error to the nearest Agilent Technologies sales or service office.
- 606 Media is corrupt
- A save was attempted to a corrupt device.
- 604 PSA only
607 ESA only File name error
- File name error; Directory does not have a default file type
- File name error; Directory does not support extenders
- File name error; Empty filename
- File name error; Illegal extender
- File name error; Illegal filename character
- File name error; Only one: is allowed
- File name error; Only one extender character allowed
- An invalid file name was specified. Use filenames with a maximum of 8 characters (letters and digits only), and use a 3-character extension. File names are not case-sensitive. This error also occurs if you try to delete a nonexistent file.
- 608 Mass storage error; EEPROM write timeout
- 609 Restoration of NVRAM data
- This error indicates that a file stored in Non-Volatile RAM has been corrected based on the Hamming codes stored with the file. After the correction, the file will contain the same data as when the instrument was shut off. If this error continues to occur on successive power cycles, it may indicate that there is a problem with the physical memory.
- 627 PSA only
609 ESA only Media is not writable
- A save was attempted to a read-only device or device that could not be written to. Try a known-good disk.
- 610 File access is denied
- The file is protected or hidden and cannot be accessed.

- 611 File access IO busy;
duplicate :SERVICE[:PRODUCTION]:CALIBRATE:BEGIN

File access IO busy; :SERVICE[:PRODUCTION]:CALIBRATE:END
without a BEGIN
- 601 PSA only
612 ESA only File not found

The analyzer could not find the specified file.
- 613 Flash memory is full

The internal flash memory is full. Clear some space by deleting unwanted files. If your analyzer has a serial number less than US41440000 or MY41440000 and Option B72 has not been installed, you may also increase the flash memory size by purchasing Option B72.
- 763 PSA only
614 ESA only Bad, missing, or unformatted disk

Bad or missing floppy disk

The floppy disk is not inserted properly, is not formatted, or the directory cannot be read. Insert a known good disk and try again.
- 615 PSA only
604 ESA only File already exists

File exists

You attempted to save to a file that already exists. Either delete or rename the existing file or select a new name, then try again.
- 603 PSA only
615 ESA only File is corrupt

Corrupted file

The file that you were trying to load is corrupt.
- 617 Wrong density floppy inserted

The floppy disk has the wrong density. It should be 1.44 MB.
- 618 Illegal write access of Flash memory

Attempt to write to an unavailable area of internal flash memory.
- 619 Can't Auto-Couple RBW in Zero Span

You sent a remote command to set the RBW into auto while in zero span.
- 620 Can't Auto-Couple Sweep Time in Zero Span

You sent a remote command to set the sweep time to auto while in zero span.

- 622 External reference missing or out of range
The external frequency reference signal is missing, has too low an amplitude, or does not match the frequency value that you previously entered into instrument memory.
- 623 Printer not responding
Printer not responding; ioctl ERROR
Check the printer. It may not be connected properly or turned on.
- 625 Printer out of paper
Load paper in printer.
- 626 Print failed; Can't open print file desc
Print failed; DisplayExport can't create print file
Print failed; DisplayExport illegal print language
Print failed; DisplayExport insufficient RAM space
Print failed; DisplayExport undetermined error
Print failed; Error transferring image to printer
Print failed; Printer ioctl failed
Print failed; Unknown printer response
- 627 PSA only
609 ESA only Media is not writable
A save was attempted to a read-only device or device that could not be written to. Try a known-good disk.
ERROR/NUMBER "609 Restoration of NVRAM data" IS ALREADY USED FOR HAPPENING ./storage/directory/NRAM_Directory.cc HAP_nramDataCorrected
- 651 Connect RF OUT to INPUT
Attempt to align the tracking generator without its output connected. Connect the tracking generator RF OUT to the analyzer **INPUT**.
- 652 Connect AmpTpd Ref Output to Input
For Agilent Technologies E4402B, E4403B, E4404B, E4405B, E4407B, and E4408B only: you must connect the **AMPTD REF OUTPUT** to the analyzer **INPUT** with the appropriate cable.
- 653 Auto Align not available when using Calibration Defaults
The Auto Alignment system cannot be used until an **Align Now All** is executed by pressing **System, Alignments, Align Now, All**. On all Agilent Technologies ESA spectrum analyzer models except Agilent Technologies E4401B and E4411B, you must connect the **AMPTD REF OUT** to the **INPUT**

with the appropriate cable to perform this alignment. *For Agilent Technologies E4401B and E4411B only:* disconnect any signals from the **INPUT** prior to performing this procedure.

- 701 Invalid printer response
- In attempting to identify the printer an invalid response was received. Check that you are using a supported printer. Be sure you are using the proper cable and that it is securely fastened.
- 702 Unsupported printer
- A printer which is recognized, but known to be unsupported was identified. This printer cannot be used with the analyzer. For example, a printer only supported by Microsoft Windows will generate this error.
- 703 Unknown printer
- In attempting to identify the printer, a valid response was received but the printer is not known to the analyzer. Use the **Custom** printer menu under **Print Setup** to configure the printer.
- 704 Printer interface error
- An error occurred while trying to print. Make sure the printer is turned on and properly connected.
- 705 Printer Type is None
- The current printer type is set to **None**, so no print operations are possible. Change the type in the **Print Setup** menu and try again.
- 727 In <filename>: [DATA] header missing
- This message indicates that the data section of a file did not begin with the token **[DATA]**.
- 728 In <filename>, line <nnn>: separator missing
- The **[HEADER]** section of a file contains entries requiring an equal (=) sign, such as <keyword> = <value>. This message appears if the equal sign does not appear on the line.
- 729 In <filename>: error reading file
- Appears when loading data from a limit line or corrections disk file and a failure to the file occurs.
- 730 In <filename>, line <numeric_value>: line too long
- When loading data from a limit line or corrections disk file, this message will appear if the length of any line in the file exceeds 255 characters.
- 731 In <command>: bad data count (<numeric_value>): expected multiple of <numeric_value>
- This message indicates that the data sent to a corrections or limit table via the **DATA** or **MERGE** commands does not have the expected length for the

table. For example, this message would appear if an attempt were made to merge 7 numeric values into a limit table, since each logical entry requires 3 values (frequency, amplitude, and connected).

- 732 In <filename>, line <numeric_value>: error parsing tokens
- This message may appear when loading data from a limit line or corrections disk file. It indicates a problem in the attempt to break a string of text into tokens. There may be too few tokens in the string. In other words, the file content must match the expected format. This typically happens when there are too few numeric values in the [DATA] section of a limit or corrections file.
- 733 In <filename>, line <numeric_value>: <xxx> is not numeric
- This message may appear when loading data from a limit line or corrections disk file. It indicates that a non-numeric token <xxx> was found where a numeric token was expected. In other words, the file content must match the expected format.
- 734 Interpolation error: cannot compute log of <negative_frequency_value>
- Occurs when the frequency interpolation of a limit line is set to log and the start frequency of the instrument is negative. The <negative_frequency_value> is limited to - 80 MHz, so it may not match the frequency that caused the error.
- 735 In <filename>: bad amplitude unit <unit>
- This message indicates that unit <unit> is not recognized or supported.
- 736 Too many data values at <freq_or_time_value>
- This message may appear when data is sent to a corrections or limit table using the **DATA** or **MERGE** commands. These tables limit the number of amplitudes associated with a frequency or time to 2 or less. This message will appear if an attempt is made to attach 3 or more values to a frequency or time.
- 751 Instrument state set to initial values
- Instrument state may be corrupt, state has been reset to initial values
- While trying to load a trace or state, the state information was found to be in error. This may be because the state had been stored on a later revision of analyzer firmware. A default set of state variables was loaded instead. There is nothing wrong with the analyzer.
- An error in the internal instrument state has been detected. The state has been reset to a default value.
- 752 Unable to load state from file
- Attempt to load a state from a file failed.

- 753 Unable to save state to file
Attempt to save a state to a file failed. See the associated error messages for the cause (press **System, Show Errors**).
For PSA: If this error occurs after a mode switch that takes longer than normal, you may need to free up some instrument memory. When you switch to a different measurement mode, the analyzer must temporarily store instrument state data. If you have less than 500 kB of available memory, the switching process can take over 1 minute and result in this error. Use the File key menu to delete any unnecessary files from instrument memory.
- 755 Unable to load state from register
Attempt to load a state from an internal state register failed.
- 756 Unable to save state to register
Attempt to save a state to an internal state register failed. See the associated error messages for the cause (press **System, Show Errors**).
- 757 Unable to load user state, factory preset was done
A user preset failed, so the factory preset values were used. Save a valid state into user preset and try again.
- 758 Unable to save user state
Attempt to save a user preset state failed. See the associated error messages for the cause (press **System, Show Errors**).
- 759 Unable to load state saved from firmware Rev A.xx.xx; Restore Sys\nDefaults
Unable to load state
A saved state file from a newer firmware revision was attempted to be loaded into an older instrument.
- 760 ESA only Unable to query state
Query of state over the remote interface was unsuccessful.
- 761 ESA only Unable to set state
Attempt to set the state over the remote interface was unsuccessful.
- 762 ESA only Incorrect filename, allowable extensions are .trc or .csv
Attempt to save a trace to a file with an incorrect extension.
- 762 ESA only Unable to load file
A failure occurred while loading a file; the file was not loaded.

- 763 PSA only
614 ESA only Bad, missing, or unformatted disk
Bad or missing floppy disk
The floppy disk is not inserted properly, is not formatted, or the directory cannot be read. Insert a known good disk and try again.
- 763 ESA only Incorrect filename, allowable extensions are .gif or .wmf
Attempt to save a screen image to a file with an incorrect extension.
- 764 Unable to save file
Attempt to save a file failed; the file was not saved. See the associated error messages for the cause (press **System, Show Errors**).
- 765 Unable to load file
Attempt to load a file failed; the file was not loaded.
- 766 Unable to format drive
- 767 Failed to Initialize ISTATE regions. Fatal LDS error
Attempt to initialize the instrument state has failed. Cycle instrument power. If this fails to correct the problem, contact your nearest Agilent Technologies service center.
- 768 Unable to load user state, required instrument mode is not installed
Attempt to load a state failed, because the state was saved with a measurement personality that is not currently loaded. Load the appropriate personality and try again.
- 769 ESA only Invalid instrument mode
You have attempted to switch to an instrument mode that is currently not installed. Confirm that the mode name (for INST:SEL) or number (for INST:NSEL) was entered correctly and that the requested personality is actually installed in the instrument.
- 770 Incorrect filename, allowable extensions are .gif or .wmf
You sent a remote command to save a screen file but did not specify a valid extension.
Incorrect filename, allowable extension is .sta
You sent a remote command to save a state file but did not specify a valid extension.
Incorrect filename, allowable extensions are .trc or .csv
You sent a remote command to save a trace file but did not specify a valid extension.

- 770 Instrument mode requested is not supported
Instrument mode specified with: INST command is not valid. Refer to Chapter 5, “Instrument Subsystem” of *Agilent Technologies ESA Series Spectrum Analyzer Programmer’s Guide* for more information.
- 771 Store Ref trace before turning on Normalize
A reference trace must be available for the Normalize function to be activated. Refer to “View/Trace” in the *Agilent ESA Spectrum Analyzer User’s Guide* where the **Normalize** key function is explained in detail.
- 772 Cannot load a directory
Cannot load a directory, please choose a file
You have selected a directory instead of a file when attempting to perform the Load function under the **File** front-panel key.
- 780 No Peak Found
- 781 Video Trigger cannot be active with Average Detector
You sent a remote command to do one of the following:
- Turn on video trigger while the Average Detector or a Marker Function is active.
 - Turn on the Average Detector or a Marker Function while Video Trigger is active.
- 782 Video Trigger cannot be used with Mkr Func due to Average Detector
- 783 Allowable span for current center frequency exceeded
- 784 Allowable CF for current span exceeded
- 786 Cal file not initialized correctly, <filenumber>
This indicates that an older LO board is loaded in, with uninitialized values for the milli-meter band edges in it's EEPROM band edge cal file. This happening is will therefore only be visible in the service mode.
- 787 WBIF Self Test Failed
Pot 122 performs a loop-back self-test on power up. It does an ADC image calibration, then stores a sine wave in RAM and plays it out the DAC. It then measures the carrier power, image rejection and signal-to-noise ratio. If this test fails, the wideband digitizer hardware is either incorrectly installed or has a hardware failure. Call your Agilent Service representative.
There is diagnostic information available. The self test can be run with DIAG:WBIF:TEST? This command returns 4 values: passed, carrier power, image rejection and signal to noise ratio.
First look at the carrier power. If it is below –50, the LVDS cable is

probably missing or faulty. If the carrier power is above 0 dBm, image rejection less than 40 but SNR more than 50, there is probably a bad ADC.

- 788 WBIF ADC Image Calibration Failed
- The Opt 122 card uses two ADC's that must be kept in perfect synchronization to avoid unwanted images appearing in the spectrum. The instrument will occasionally perform an ADC Image Calibration (formerly known as Step Cal) to resynchronize the ADC's. This calibration is only known to fail if there is a hardware problem.
- 789 WBIF Firmware Reset
- Option 122 has a local microprocessor controlling the hardware trigger. If this microprocessor resets, it will automatically restart and begin taking data again, and will send this error message. While this should never happen, it is a self-recovering error that requires no action on the part of the user. If, however, it starts to occur frequently, contact your Agilent service representative to find out if there is a firmware upgrade to solve the problem.
- 791 Acquiring Data...
- WBIF Power On Test Failed
- An error occurred when the Option 122 wide bandwidth IF hardware was tested during the power on process.
- 795 No trigger before timeout; auto-triggered
- 797 Awaiting Trigger, no AUTO Trig
- 801 Memory limit caused Data Acquisition to be truncated
- 805 doing Alignment...

Greater than 10000: Measurement Applications Errors

NOTE Error numbers are displayed in the error queue, *not* on the display.
 To see an error *number*, press **System, Show Errors**.

10008 to 10517: Power Suite Error Messages An error number in this range indicates the instrument has detected an error relating to the Power Suite functionality.

- 10008 Preferred resolution bandwidth not available.
- The calculated required resolution bandwidth for this measurement is not available.

- 10010 One or more harmonics past freq limit: number decreased.
Highest harmonic was past the frequency limit of the analyzer, so the number of measured harmonics was decreased.
- 10011 First harmonic is past analyzer frequency limit.
First harmonic was past the frequency limit, so no harmonics can be measured. The analyzer will simply measure the fundamental. If you have an Option AYZ it allows the use of Agilent 11970 Series, and Agilent 11974 external mixers to extend the frequency range to 110 GHz. Operation to 325 GHz is also possible with non-Agilent mixers.
- 10012 No Fundamental > 0 Hz found in given span.
There were no frequencies greater than 0 Hz in the starting span, so the centre frequency at measurement entry will be used as the fundamental.
- 10013 No Fundamental > -50 dBm found in given span.
There was no fundamental found, so the centre frequency at measurement entry will be used as the fundamental.
- 10020 Signal Tracking is not available when Noise Correction is on.
If signal tracking is turned on while noise correction is on, it will be turned off. To use the signal tracking function, first turn noise correction off.
- 10138 Valid GSM burst not found in frame (Burst Type)
No active GSM bursts that match the selected burst type have been detected in the RF input signal. Search was performed over a complete GSM frame.
- 10139 Valid GSM burst not found in specified timeslot (Burst Type)
No active GSM bursts that match the selected burst type have been detected in the RF input signal. Search was performed over the specified timeslot.
- 10140 Valid GSM burst not found in frame (Ref Burst)
No active GSM bursts that match the selected burst type have been detected in the RF input signal. Search was performed over the specified complete GSM frame using the Ref Burst type setting.
- 10141 Sync word not found in frame (Burst Type)
One or more active GSM bursts that match the selected burst type have been detected in the RF input signal, but none contain the selected Training Sequence Code (TSC). The search was performed over the complete GSM frame.

- 10142 Sync word not found in specified timeslot (Burst Type)
One or more active GSM bursts that match the selected burst type have been detected in the RF input signal, but none contain the selected Training Sequence Code (TSC). The search was only performed over the specified timeslot setting.
- 10143 Sync word not found in frame (Ref Burst)
One or more active GSM bursts that match the selected burst type have been detected in the RF input signal, but none contain the selected Training Sequence Code (TSC). The search was only performed using the Reference Burst type and the Ref TSC settings over the complete GSM frame.
- 10144 Unknown demod status
Demodulation is in an unknown state. Press **Preset**. If the error persists, get in touch with your service center.
- 10145 Opt AYX hardware required. Meas unavailable.
Option AYX must be installed for this measurement to be enabled.
- 10146 Options B7D & B7E hardware required. Meas unavailable.
The RF Communications Hardware (Option B7E) and Digital Signal Fast ADC (Option B7D) cards required to perform the demodulation are not present in the analyzer.
- 10147 Opt B7D bootrom requires upgrade.
The (Option B7D) bootrom revision is not supported by the currently loaded personality version. Refer to the user's guide for the personality in use.
- 10148 Opt BAH DSP algorithm files not installed. Meas unavailable.
Contact your Service Center.
The Digital Signal Processor algorithm files required to perform the demodulation are not present in the analyzer.
- 10148 B7D DSP Code Fail. Reload Opt BAH. Contact your Service Center.
The Digital Signal Processor algorithm files required to perform the demodulation are not present in the IDSP: drive.
- 10149 Opt BAH DSP algorithm code file requires upgrade.
The Digital Signal Processing algorithm code file revision is not supported by the currently loaded personality version. Refer to the user guide for the personality in use for more information on installation/upgrade.

- 10150 Opt BAH DSP algorithm coef. file requires upgrade.
The Digital Signal Processor algorithm coefficient file revision is not supported by the currently loaded personality version. Refer to the user guide for the personality in use.
- 10151 Opt BAH DSP algorithm files failed to load, aborting measure.
The Digital Signal Processor algorithm files required to perform the demodulation are corrupt and cannot be loaded properly. Reinstall measurement personality.
- 10151 B7D DSP Code Fail. Reload Opt BAH. Contact your Service Center.
The Digital Signal Processor algorithm files required to perform the demodulation are present in the IDSP: drive and cannot be loaded properly into DSP RAM. Reinstall measurement personality.
- 10152 Lost trigger, aborting measurement.
The selected trigger source was present at the start of the measurement, but timed out before the measurement completed.
- 10153 DSP algorithm timeout, aborting measurement
The Digital Signal Processor demodulation algorithm timed-out for an unknown reason. This message normally indicates a problem with the modulated signal.
- 10154 Measurement not defined for Out of Band.
You have changed to an out-of-band frequency range. The band measurement only operates in the selected band.
- 10155 No Fast ADC hardware installed. Meas unavailable.
The analyzer cannot use sweep times of less than 5 msec when Option B7D or Option AYX is not installed. Therefore, the measurement will not be executed.
- 10156 No Fast ADC hardware installed.
The analyzer cannot use sweep times of less than 5 msec when Option B7D or Option AYX is not installed resulting in all the radio standards not being supported.
- 10156 The calibration data is invalid, and has been cleared.
- 10157 Tracking Generator hardware is not present. Meas unavailable.
The measurement requires a built-in tracking generator.
- 10158 This operation requires a measurement to be active.

- 10159 Entire trace is below threshold level
The measurement cannot operate properly because the trace has completely fallen below the threshold level. Change the threshold level to view trace.
- 10160 Valid burst not found
Cannot find a valid burst, either because it is not fully on the display, or the level is too low to be detected properly.
- 10160 Upper Custom Mask is Invalid!
The user-specified upper custom mask cannot be resolved into a limit line. The format may be bad.
- 10161 No Fast ADC hardware installed.
Cannot use sweep times less than 5 ms, due to the lack of a fadc, therefore the meas will be severely restricted.
- 10161 Lower Custom Mask is Invalid!
The user-specified lower custom mask cannot be resolved into a limit line. The format may be bad.
- 10162 Resolution BW <300 kHz.
This error message is a warning that the resolution bandwidth has been set below 300 kHz. The test results will not meet GSM specifications.
- 10163 Cannot find the Power vs Time Limits File.
The limit line definition file for the GSM standards has been deleted. This message is displayed while the **Measure** key is grayed out. Reinstall the GSM measurement personality.
- 10164 Band Measurement not defined for Out of Band.
You are attempting to monitor the band but have set the frequency outside the band. Reset the band for the particular standard for which you are testing or use the channel setting which does not require a frequency to be set. (**Meas Setup, Method (Channel)**).
- 10165 Carrier Not Present.
- 10166 Cannot update the list of cable types.
The cable file may have been moved or deleted accidentally. Reinstall the measurement personality. This message is applicable to the GSM (Option BAH) and Distance to Fault (Option 226) measurement personality options.

- 10166 Cannot locate the file that contains the list of cable types.
The cable file may have been moved or deleted accidentally. Reinstall the measurement personality. This message is applicable to the GSM (Option BAH) and Distance to Fault (Option 226) measurement personality options.
- 10167 The file containing the list of cable types has been updated.
- 10168 Cannot update the list of cable types on drive C:
The file update failed.
- 10170 The Cable Fault Measurement is active. Mode Setup is disabled.
Mode setup is not available in the cable fault utility.
- 10172 Sweep Time too fast (<2 sec)
The sweep time must be set to 2 seconds or longer for the results to be valid.
- 10173 Carrier Not Present.
- 10177 There are no spurs to inspect.
You have attempted to switch the **Inspect Spur** menu key to the **On** position after the measurement has finished, but found no spurs.
- 10178 Carrier Not Present.
- 10179 Carrier Present. Test Stopped!
A carrier was found in the transmit band. Either disable the carrier or insert a bandpass filter for the receive bandwidth.
- 10180 Gate option not installed. Results may not be accurate.
This measurement method requires the use of the time-gate (option 1D6) in order to gate the spectrum during the 50-90% part of the burst. If the gate option is not installed, the measurement will still run although this warning will be displayed.
- 10181 Upper Custom Mask is Invalid!
The user-specified upper custom mask cannot be resolved into a limit line. The format may be bad.
- 10182 Lower Custom Mask is Invalid!
The user-specified lower custom mask cannot be resolved into a limit line. The format may be bad.

- 10183 Resolution BW <300kHz.
The test will not meet EDGE specifications because the resolution BW has fallen below 300 kHz.
- 10184 Cannot find the Power vs Time Limits File.
Cannot find the limit line definition file for the EDGE standards. This message is displayed while the **Measure** key is greyed out.
- 10185 Gate option not installed. Results may not be accurate.
- 10186 Measurement does not support the current radio standard.
The measurement you have chosen is currently greyed out. Select a radio standard which is supported or configure this measurement manually (**Mode Setup, Radio Std. None**).
- 10186 EDGE EVM only supports EDGE TCH burst type (Burst Type)
- 10187 Radio standard is not supported by the current measurement.
The standard you have chosen is currently greyed out. Select a radio standard which is supported by the current measurement or configure this measurement manually (**Mode Setup, Radio Std. None**).
- 10187 EDGE ORFS only supports EDGE TCH burst type (Burst Type)
- 10188 EDGE PVT only supports EDGE TCH burst type (Burst Type)
- 10189 EDGE PVT only supports EDGE TCH burst type (Ref Burst)
- 10190 Select a valid Radio Standard/Measurement combination to enable.
The Enable All Measurements menu key was pressed when it was disabled. To enable select a radio standard that is supported by the current measurement or a measurement that supports the current radio standard.
- 10190 EDGE ORFS only supports EDGE TCH burst type (Ref Burst)
- 10191 Mask unavailable for current Span - increase to display mask.
The current span setting is either narrower than the mask width or so wide that there are too few display points to allow the mask to be drawn. Increase or decrease the span to display the mask.
- 10191 EDGE EVM only supports EDGE TCH burst type (Ref Burst)
- 10192 Sweep Point/Span ratio below minimum - results may be inaccurate.
The sweep point to span ratio is below the minimum required to ensure the bucket ratio is large enough to test DVB-T masks.

- 10218 Hardkeys are disabled.
- Some of the forms (for example Receiver Spurious in GSM) do not allow you to close the form without either formally accepting or cancelling the form settings. For this reason, all of the hardkeys are disabled until you terminate the form.
- 10219 Awaiting trigger
- The measurement requires a trigger to be present. If the trigger does not occur or is delayed, this message will be displayed. Check your trigger settings.
- 10220 Preselector cannot be bypassed in this mode.
- The Option 123 allows the microwave preselector to be bypassed. This functionality is not available from within either the Phase Noise or Noise Figure application modes. If the preselector is set to off, it will immediately be forced back to On.
- 10227 Measurement suspended until carrier is turned off.
- The receive channel power and the receive spur measurements are specified with the attenuation set to 0 dB. To prevent overload, the frequency spectrum of interest is monitored for signal levels which exceed a specified threshold before setting the attenuator to 0 dB. If a carrier is found, this message is displayed and the completion of the measurement will not occur until the carrier is removed. The carrier check may be turned off using the properties form under the front-panel **Mode Setup** key. You may also change the signal threshold which determines a carrier on the properties form.
- 10228 Cannot correlate to input signal.
- This error is normally generated because of one of the following reasons:
1. There is no carrier signal.
 2. Walsh channels other than the pilot are active.
 3. There is some other modulation problem that will prevent the measurement from being made.
- This problem must be corrected before the measurement can continue.
- 10229 The regression portion failed.
- This message occurs when (Option B7D) is not functioning properly. Demodulation measurements (modulation accuracy and code domain) might fail as a result of this error.
- 10230 DSP timed out, resetting DSP.
- Digital Signal Processor was unable to finish the selected measurement within the given period of time. Restart the measurement.
- 10231 Measurement failed for unknown reasons.
- Check instrument settings and restart measurement.

- 10232 RF Signal not found.
This message is generated if there is no signal at the center frequency that is greater than 10 dB above the displayed average noise level.
- 10233 Level is low, results may degrade.
The signal being measured is of low power. The results may not be as accurate as they would be if the signal level was higher.
- 10237 RF Board LO Unlocked. Contact service center.
This message occurs if the local oscillator on the (Option B7E) is in an unlocked state. This indicates broken hardware.
- 10238 RF Board SR Osc Unlocked. Contact service center.
This message occurs if the sample rate (SR) oscillator on Option B7E is in an unlocked state. This indicates broken hardware.
- 10239 Opt Freq Ref setting does not match external reference.
This message is generated if Source is set to External on the properties form under the front-panel **Mode Setup** key and the frequency on the same form is set to a frequency that does not match the frequency of the signal being used as the external reference.
- 10240 RF Board RF Osc Unlocked. Contact service center.
This message occurs if the reference oscillator on the (Option B7E) is in an unlocked state. This indicates broken hardware.
- 10241 RF Board could not detect any bursts in signal.
This message is generated when the trigger is set to RF Burst and (Option B7E) cannot detect a burst.
- 10245 Error reading file: SPCLIMIT.CSV. Cannot use custom limits.
The file could be missing or corrupt. Create a new limits file. Alternatively, the actual limits defined in the file might not allow the measurement to be executed. Redefine the limits or use the default limits. Restart the measurement.
- 10246 Error reading file: CDMASTUN.CSV. Please reinstall cdmaOne.
The file is missing or corrupt. Please reinstall the cdmaOne personality.
- 10247 Error reading file: CDPMDA. Please reinstall cdmaOne.
The file is missing or corrupt. Please reinstall the cdmaOne personality.
- 10248 Error reading file: CDPPMCO. Please reinstall cdmaOne.
The file is missing or corrupt. Please reinstall the cdmaOne personality.
- 10249 Error reading file: CDPPMDA. Please reinstall cdmaOne.
The file is missing or corrupt. Please reinstall the cdmaOne personality.

- 10250 Error reading file: RHODMDA. Please reinstall cdmaOne.
The file is missing or corrupt. Please reinstall the cdmaOne personality.
- 10251 Error reading file: RHOPMCO. Please reinstall cdmaOne.
The file is missing or corrupt. Please reinstall the cdmaOne personality.
- 10256 Error reading file: OOBSTAB.CSV. Use Edit Table | Save Table.
This error is generated when you try to load a table (using the **Load Table** key on page 2 of the edit table form menu) before a table has been saved. You must first save a table using the **Save Table** key before trying to load a table using the **Load Table** key.
- 10259 Table could not be saved.
This message occurs if the C: drive is full or corrupt. Check the amount of space left on the drive.
- 10260 Table could not be loaded.
When trying to load a table, the previous table has been somehow corrupted. Use the **Save Table** key to save a valid table. Then edit the valid table, save it, and try to load it again.
- 10264 Emission bandwidth not found. Consider increasing span.
This error is normally generated when attempting occupied bandwidth measurements. The “X dB” value you entered (**Meas Setup, X dB**) to calculate the emission bandwidth is the difference between the highest point on the trace and the point “X dB” down on either side of the maximum. If the actual difference is less than the value entered, the emission bandwidth cannot be computed. Some responses to this situation are as follows:
1. Connect a signal to the input. (If there is no signal present, the difference between the trace minimum and maximum will generally be less than “X dB”.)
 2. Increase the span. (If the signal is wide, the shoulders of the signal might not be present on the screen, and again, the difference between the trace minimum and maximum will be less than “X dB”.)
 3. Center the signal. (There must be a point on the trace that is “X dB” down from the maximum on both sides of that maximum.)
- 10286 Burst not found.
Either the signal being analyzed has insufficient power, the rising or falling edges cannot be detected, or the burst is less than 126 microseconds.
- 10287 Valid Bluetooth burst not found. (Check Packet Type)
The burst that has been found does not correspond to the currently selected Bluetooth packet type (the burst length may be too short).

- 10288 Option B7D or AXX FADC hardware required. Meas unavailable.
The measurement you are attempting requires either the DSP and Fast ADC (Option B7D) or the Fast ADC (Option AXX) card to perform the demodulation, but neither are present in the analyzer.
- 10289 Opt 106 demod hardware required. Meas unavailable.
A demod measurement was attempted with no Bluetooth FM demod card present (Option 106).
- 10290 Parameter unavailable in demod measurements.
You have selected (by remote SCPI command) either RF Amplitude sync or Video trigger while running one of the demod measurements.
- 10291 Opt B7E RF hardware required. RF Burst unavailable.
You have selected (by remote SCPI command) RF Burst Trigger with no digital demodulation RF card present (RF Communications Hardware (Option B7E)).
- 10320 Opt 106 hardware required. Preamble sync unavailable.
You have selected (by remote SCPI command) preamble sync with no Bluetooth FM demodulation card present (Option 106).
- 10321 Start Marker must be at least 1% < Stop Marker.
You have attempted to input a start marker value that will result in the difference between the start and stop markers being less than 1%.
- 10322 Stop Marker must be at least 1% > Start Marker.
You have attempted to input a stop marker value that will result in the difference between the start and stop markers being less than 1%.
- 10323 Unable to Calculate Result using Current Setup.
You have changed the setup parameters such that the marker lines used to measure the power cannot be displayed therefore accurate measurements cannot be made.
- 10340 '10101010' pattern not detected - results may be inaccurate.
This message is displayed if the measurement cannot detect the '10101010' pattern in the payload. The measurement will continue and carry out the calculations on the payload data supplied, but may not be correct.
- 10350 Payload data pattern '10101010' not present.
This message is displayed when the "Payload Data" parameter is set to Auto and the measurement has not detected either of the required patterns in the payload.

- 10351 Required payload data pattern '10101010' not present.
This message is displayed after successfully measuring and holding the '11110000' pattern if the measurement is restarted and the '10101010' data pattern is not detected.
- 10352 Required payload data pattern '11110000' not present.
This message is displayed after successfully measuring and holding the '10101010' pattern if the measurement is restarted and the '11110000' data pattern is not detected.
- 10353 There is no valid result to hold.
You have attempted to hold either $\Delta f1$ or $\Delta f2$ before it has been measured.
- 10360 Can't compute result - not enough transitions.
This message is displayed when the measurement cannot find either a 111, 000, 101 or 010 pattern and is therefore unable to calculate the low or high frequency deviations.
- 10389 Valid EDGE burst not found in frame (Burst Type)
No active EDGE bursts that match the selected burst type have been detected in the RF input signal. Search was performed over the complete EDGE frame.
- 10390 Valid EDGE burst not found in specified timeslot (Burst Type)
No active EDGE bursts that match the selected burst type have been detected in the RF input signal. Search was performed over the specified timeslot.
- 10391 Valid EDGE burst not found in frame (Ref Burst)
No active EDGE bursts that match the selected burst type have been detected in the RF input signal. Search was performed over the specified complete EDGE frame using the Ref Burst setting.
- 10392 B7D DSP Code Fail. Reload Opt. 202. Contact your Service Center
The DSP algorithm files required to perform the demodulation are not present in the instrument ISDP: drive.
- 10393 Opt 252 DSP algorithm code file requires upgrade.
- 10394 Opt 252 DSP algorithm coef. file requires upgrade.
- 10395 B7D DSP Code Fail. Reload Opt. 202. Contact your Service Center.
The DSP algorithm files required to perform the demodulation are present in the instrument ISDP: drive, but cannot be loaded properly into DSP RAM.

- 10396 EDGE Upgrade (252) unlicensed. Please contact your Agilent Sales Rep.
- 10400 Valid signal not found.
- This error is normally generated because of one of the following reasons:
1. There is no carrier signal.
 2. The carrier signal power has changed during the measurement, causing ADC to over/under range.
 3. There is some other modulation problem that will prevent the measurement from being made. This problem must be corrected before the measurement can continue.
- 10401 Valid burst not found in frame (Burst Type).
- No active bursts that match the Burst Type have been detected in the RF input signal. The search was performed over the complete frame.
- 10402 Valid burst not found in specified timeslot (Burst Type).
- No active bursts that match the Burst Type have been detected in the RF input signal. The search was only performed over the specified timeslot setting.
- 10403 Sync word not found in frame (TSC).
- One or more active EDGE bursts that match the Normal Burst Type have been detected in the RF Input signal, but none contain the selected Training Sequence Code (TSC). The search was performed over the complete EDGE frame.
- 10404 Sync word not found in specified timeslot (TSC).
- One or more active EDGE bursts that match the Normal Burst Type have been detected in the RF Input signal, but none contain the selected Training Sequence Code (TSC). The search was only performed over the specified timeslot setting.
- 10409 Wideband calibration not valid until Align Now, All performed.
- Wideband calibration corrections cannot be applied to current demodulation results. Results will not meet specified demodulation performance levels until an Align Now, All has been performed.
- 10410 Measurement uncalibrated, wideband calibration required.
- Wideband calibration corrections cannot be applied to the current demodulation results. Results will not meet specified demodulation performance levels until **Wideband Cal** has been selected and successfully performed.

- 10411 Measurement uncalibrated, symbol rate exceeds +/-10% nominal.
Wideband calibration corrections cannot be applied to current demodulation results, due to the **Symbol Rate** setting exceeding +/-10% of the nominal value. Results may not meet specified demodulation performance levels.
- 10412 Cal Data corrupt. Wideband cal failed. Using previous data.
Wideband calibration procedure failed for an unknown reason. New calibration data was not saved. Previous wideband calibration data is being used, if available. However, it is not acceptable. Before re-attempting Wideband Cal, ensure connection between the **AMPTD REF OUT** and the **INPUT 50 Ω** is in place. If the error persists, get in touch with your service center.
- 10413 B7D DSP Code Install Fail Opt.229. Contact your Service Center.
The Digital Signal Processor algorithm files required to perform the demodulation are not present in the analyzer. Reinstall the measurement personality and contact your service center.
- 10414 Opt 229 DSP algorithm code file requires upgrade.
The Digital Signal Processing algorithm code file revision is not supported by the currently loaded personality version. Refer to the user guide for the personality in use for more information on installation/upgrade.
- 10415 Opt 229 DSP algorithm coef. file requires upgrade.
The Digital Signal Processor algorithm coefficient file revision is not supported by the currently loaded personality version. Refer to the user guide for the personality in use for more information on installation/upgrade.
- 10416 B7D DSP Code Reload Fail Opt.229. Contact your Service Center.
The Digital Signal Processor algorithm files required to perform the demodulation are corrupt and cannot be loaded properly. Reinstall the measurement personality and contact your service center.
- 10417 This operation requires a measurement to be active.
The analyzer cannot perform this operation, because it requires a measurement to be running and no measurement is running.
- 10418 Demod Format setting does not allow this value for Points/Symbol.
Invalid Points/Symbol selection attempted for the given Demod Format setting.

- 10419 Carrier Not Present.
A carrier signal/burst is expected at the analyzer input. This signal cannot be found; however, the measurement will still run. Check input signal connection.
- 10420 Valid burst not found.
This error only occurs when **RF Amptd** is selected for **Burst Sync**. It indicates that a valid burst envelope which meets the specified Burst Search Threshold was not found within the specified Burst Search Length. Note that the demodulation measurement will proceed by attempting to demodulate the signal without Burst Sync alignment. Possible causes may be:
1. Carrier signal is not actually bursted.
 2. Burst Search Threshold and/or Burst Search Length may need to be adjusted.
- 10421 Cannot lock to carrier.
This error only occurs when attempting to demodulate OFFSET QPSK signals. It indicates that the demodulation algorithm is unable to lock to your signal. Possible causes may be:
1. There is no carrier signal.
 2. Carrier signal is present, but Demod settings do not match the modulation format of the OFFSET QPSK signal being measured.
 3. OFFSET QPSK signal is too noisy to achieve carrier lock.
- 10425 B7D DSP Code Install Fail Opt.231. Contact your Service Center.
The Digital Signal Processor algorithm files required to for the 89600 VSA SW are not present in the analyzer. Reinstall the measurement personality and contact your service center.
- 10426 Opt 231 DSP algorithm code file requires upgrade.
The Digital Signal Processing algorithm code file revision is not supported by the currently loaded personality version. Refer to the user guide for the personality in use for more information on installation/upgrade.
- 10427 Opt 231 DSP algorithm coef. file requires upgrade.
The Digital Signal Processor algorithm coefficient file revision is not supported by the currently loaded personality version. Refer to the user guide for the personality in use for more information on installation/upgrade.

- 10428 B7D DSP Code Reload Fail. Opt.231. Contact your Service Center.
The Digital Signal Processor algorithm files required for the 89600 VSA SW are corrupt and cannot be loaded properly. Reinstall the measurement personality and contact your service center.
- 10450 Avg Mode changed to Repeat for Full Meas Type.
Meas Type has been changed to Full. Exponential Average Mode is not available for Full Meas Type therefore Average Mode has been changed to Repeat.
- 10451 Avg Mode changed to Exp for Examine Meas Type.
Meas Type has been changed to Examine. Repeat Average Mode is not available for Examine Meas Type therefore Average Mode has been changed to Exponential.
- 10452 Meas Type changed to Examine for Exp Avg Mode.
Average Mode has been changed to Exponential. Full Meas Type is not available for Exponential Average Mode therefore Meas Type has been changed to Examine.
- 10453 Meas Type changed to Full for Repeat Avg Mode.
Average Mode has been changed to Repeat. Examine Meas Type is not available for Repeat Average Mode therefore Meas Type has been changed to Full.
- 10454 Valid burst not found.
Cannot find a valid burst, either because it is not fully on the display, or the level is too low to be detected properly.
- 10509 Did not find 4 signals > Peak Excursion.
Require 4 Signals > PEAK EXCURSION above Threshold.
Using the current instrument settings, the measurement cannot locate four signals with enough energy or resolution to perform an accurate measurement.
- 10510 Signals to not fit expected Intermod (TOI) pattern.
Based on the current analyzer settings, the measurement cannot find two signals of high enough amplitude that can be resolved in such a manner that the third order products would lie within the measured span.
- 10511 100 spurs found. Additional spurs ignored.
There are too many spurs for the table (the limit is 100), and any additional spurs that are found will be ignored

- 10512 No spurs have been found.
You have started a measurement in examine meas type, in single or continual sweep mode, or full meas type in single sweep mode, but no spurs were found.
- 10513 No ranges are defined.
There are no active ranges in the range table. You will need to activate at least one range.
- 10514 Avg Mode changed to Repeat for Full Meas Type
Meas Type has been changed to Full. Exponential Average Mode is not available for Full Meas Type therefore Average Mode has been changed to Repeat.
- 10515 Avg Mode changed to Exp for Examine Meas Type
Meas Type has been changed to Examine. Repeat Average Mode is not available for Examine Meas Type therefore Average Mode has been changed to Exponential.
- 10516 Meas Type changed to Examine for Exp Avg Mode
Average Mode has been changed to Exponential. Full Meas Type is not available for Exponential Average Mode therefore Meas Type has been changed to Examine.
- 10517 Meas Type changed to Full for Repeat Avg Mode
Average Mode has been changed to Repeat. Examine Meas Type is not available for Repeat Average Mode therefore Meas Type has been changed to Full.
- 10518 Invalid State Register
There are only a limited number of instrument state registers/locations available.
- 10520 Command not supported
Command may not be supported configuration or with the current settings of other related functions.

10524 to 10561: Phase Noise Error Messages (Option 226) An error number in this range indicates the instrument has detected an error relating to the Phase Noise personality.

- 10524 This measurement does not support the *.CSV file format.
You cannot load or save base instrument traces, as this is not supported by the Log Plot measurement.

- 10525 Invalid format: CSV files are not supported by this measurement.
You cannot load or save base instrument traces, as this is not supported by the Log Plot measurement.
- 10525 Use View/Trace menu when loading or saving logarithmic traces.
You cannot load CSV format trace files or save traces in the CSV format in the Log Plot measurement of the Phase Noise Measurement Personality.
- 10526 Cannot display Ref Trace because it has no data.
Reference trace cannot be displayed, as there is currently no data assigned to it - use the functions under the Store Ref Trace menu, or load a trace to assign some data.
- 10527 Invalid Marker Trace. Marker moved to Raw Trace.
Cannot place markers on the reference trace, because the reference trace is currently turned off or has no data.
- 10529 Failed to Load trace. Bad file format.
The load trace operation could not be completed, as the input file was not in the expected format. You can only load traces that were previously saved using the 'Save Trace' feature.
- 10530 Trace file contains no compatible traces.
The trace file may have been created by another version of the Phase Noise personality, which uses a different trace format that is incompatible with the version you are running. Please check you are running the most up to date version of the personality.
- 10531 Trace file was created by incompatible version of Opt. 226
The trace file may have been created by another version of the Phase Noise personality, which uses a different trace format that is incompatible with the version you are running. Please check you are running the most up to date version of the personality.
- 10532 Cannot open trace file for writing. Save Failed.
Cannot write the trace file to the destination filename. This could be because the disk is full, or possibly due to a filename error. If using a floppy disk, check there is a formatted disk in the drive.
- 10533 Cannot save Trace because it contains no data.
Cannot save Ref Trace because it contains no data.
Check the Ref Trace is turned on, and contains some valid trace data.
- 10534 Trace file saved successfully.
The trace saving operation was successful.

- 10535 Carrier Not Present
No Carrier > -50 dBm found at the analyzer input within the search span.
Solution: Modify center frequency to be closer to actual carrier, or alternatively apply carrier of sufficient amplitude at the current center frequency.
- 10535 Cancellation trace is not set to Reference or has no data.
When performing phase noise cancellation, you need to supply a reference trace that will be used to cancel out the background noise of the analyzer. The reference trace must be in Reference (View) mode, and selected by the Ref Trace parameter under the Cancellation menu.
- 10536 Cancellation disabled while measuring DANL Floor.
Phase Noise cancellation does not make sense when measuring the DANL Floor, so for this reason it has been disabled.
- 10537 10537 Cancellation trace has different X-Scale to Smoothed trace.
When performing phase noise cancellation, you need to supply a reference trace that will be used to cancel out the background noise of the analyzer. The reference trace must have been measured over the same range of offsets, and on the same instrument as the current measurement being performed.
- 10560 Carrier Not Present. Verify frequency and amplitude settings.
No Carrier > -50 dBm found at the analyzer input within the search span.
Solution: Modify center frequency to be closer to actual carrier, or alternatively apply carrier of sufficient amplitude at the current center frequency.
- 10561 Signal Tracking disabled when measuring DANL Floor (Removal).
Measuring the DANL Floor with DANL Method set to Removal requires that you remove the signal and attach a load to the analyzer RF Input. Signal Tracking requires that the carrier be measured many times per measurement, so the two are inherently incompatible.

10601 to 10700: GSM and EDGE Error Messages (Options BAH and 202) An error number in this range indicates the instrument has detected an error relating to the GSM or EDGE personality.

- 10602 Sync word not found
An attempt to position a GSM trace into the mask, when not enough data was present. Try using the **Restart** key to clear the problem. This can be caused by a bad GSM burst, or the RF Sync Delay set too far.

- 10604 GSM burst out of limits
The GSM signal did not fit into the mask in the Power vs. Time measurement.
- 10606 Insufficient pre-Trig for demod - decrease Trig Delay
- 10608 Incorrect RBW for demod - change RBW
- 10610 GSM Hopping enabled, waiting for valid burst
- 10612 Invalid GSM burst timing
A GSM-like burst was acquired, but its timing is not valid. Ensure the correct **Burst Type** has been selected.
- 10614 Valid GSM burst not found
In a GSM measurement, data was acquired but a GSM burst was not found, with the timeslot mode disabled.
- 10138 Valid GSM burst not found in frame (Burst Type).
No active GSM bursts that match the selected Burst Type have been detected in the RF input signal. The search was performed over the complete GSM frame.
- 10139 Valid GSM burst not found in specified timeslot (Burst Type).
No active GSM bursts that match the selected Burst Type have been detected in the RF input signal. The search was only performed over the specified timeslot setting.
- 10140 Valid GSM burst not found in frame (Ref Burst).
No active GSM bursts that match the selected Burst Type have been detected in the RF input signal. The search was performed using the Ref Burst type setting over the complete GSM frame.
- 10616 Cannot synchronize frame trigger
Cannot synchronize the frame trigger to the even second clock.
- 10618 Dynamic range not optimum
- 10620 Cannot synchronize to RF amplitude (burst error)
- 10622 GSM RF sync delay is out of range
Change RF Sync Delay.
- 10624 Sync word not found
In a GSM measurement using demodulation, the training sequence code (sync word) could not be found.

- 10141 Sync word not found in frame (Burst Type)
One or more active GSM bursts that match the selected Burst Type have been detected in the RF Input signal, but none contain the selected Training Sequence Code (TSC). The search was performed over the complete GSM frame.
- 10142 Sync word not found in specified timeslot (Burst Type)
One or more active GSM bursts that match the selected Burst Type have been detected in the RF Input signal, but none contain the selected Training Sequence Code (TSC). The search was only performed over the specified timeslot setting.
- 10143 Sync word not found in frame (Ref Burst)
One or more active GSM bursts that match the selected Burst Type have been detected in the RF Input signal, but none contain the selected Training Sequence Code (TSC). The search was only performed using the Reference Burst type and Reference TSC settings over the complete GSM frame.
- 10626 Signal too noisy
In a GSM measurement, indicates that a burst could not be found in a signal that appears noisy.
- 10628 Sync is RF Ampl (not Training Seq). Bits not accurate
- 10630 Marker X value not adjusted when right of Rise&Fall mark
- 10632 Incorrect trigger holdoff
- 10634 Break freq > FFT filter edge
- 10636 SCPI marker query not available in GSM Rise&Fall
- 10638 GSM Pwr Meas requires trig delay < -50 μ s. Delay set to -50 μ s
- 10640 Carrier frequency outside device's transmit band
The entered channel/carrier frequency is not within the range of your current mode setup selection of standard and device.
- 10642 ADC overload -- Carrier not at expected frequency
The carrier frequency of the signal may not match the instruments channel frequency setting.
- 10644 Requested timeslot number not present
The selected timeslot is not on. (Timeslot is referenced to the trigger point.)
- 10646 Tx Band Spur measurement not defined for mobiles
Only base station testing is available.

- 10648 Carrier power too low for optimum dynamic range
For better dynamic range, transmit band spur measurements require >10 dBm signal power at the RF input port.
- 10650 Unexpected carrier frequency (BMT only)
The transmit band spur measurement only allows bottom (B), middle (M), and top (T) channel frequencies for each supported frequency band. The carrier frequency must be set to the bottom, middle or top frequency of the current frequency band.
- 10652 EVM Measurement only supports EDGE TCH burst type
- 10654 Unable to demodulate signal
- 10655 Input overload
Excessive input power has been detected which will cause the ADC to clip the signal. Reduce the signal level, change the attenuator setting (under **Input** menu), or press **Restart** if the **RF Input Range** is **Auto**.
- 10656 Tx Band Spur measurement does not support this frequency band
The transmit band spur measurement does not support all of the commercially available frequency bands. You need to change your selection under **Mode Setup, Radio, Band** to one of the supported bands.
- 10657 Pretrigger too long
- 10658 Valid GSM burst not found for selected timeslot
In a GSM measurement, data was acquired but a GSM burst was not found, with the timeslot mode enabled.
- 10701 to 10800: W-CDMA Error Messages (Option BAF)** An error number in this range indicates the instrument has detected an error relating to the W-CDMA personality.
- 10702 Signal too noisy
- 10704 Input power too low
The instrument only identifies a channel as active if it meets the default threshold criteria that it is within 20 dB of the highest power code channel. The threshold can be changed using the Active Set Threshold function in the Meas Setup menu.
- 10768 Cannot correlate to input signal
Cannot correlate to the input signal and no active channel is found. (from the composite EVM measurement) An active channel must meet the default threshold criteria that it is within 20 dB of the highest power code channel. The threshold can be changed using the active set threshold function in the Meas Setup menu.

- 10772 Burst not found.
Either the signal being analyzed has insufficient power, the rising or falling edges cannot be detected, or the burst is less than 126 microseconds.
- 10776 Cannot sync DPCCH pilot.
Cannot synchronize measurement with DPCCH pilot for Power Control measurement, because the pilot signal cannot be found. Make sure DPCCH is present in the W-CDMA uplink signal, and that the slot format and scramble code are set correctly.
- 10778 Valid PRACH burst not found.
Cannot synchronize measurement with PRACH channel for Power Control measurement, because the signal cannot be found. Make sure PRACH is present in the W-CDMA uplink signal, and that the preamble signature and scramble code are set correctly.
- 10780 Critical memory shortage occurred.
This error message appears when a critical memory shortage occurs, and the current measurement is aborted. To continue, restart the measurement by pressing the **Preset** key, or by exiting and then re-entering the current mode or the current measurement, or cycle the power.

10801 to 10900: cdma2000 Error Messages (Option B78) An error number in this range indicates the instrument has detected an error relating to the cdma2000 personality.

- 10824 Signal too noisy
- 10826 Input power too low
The instrument only identifies a channel as active if it meets the default threshold criteria that it is within 20 dB of the highest power code channel. The threshold can be changed using the Active Set Threshold function in the Meas Setup menu.
- 10868 Can not get long code phase (RS-232)
For MS (mobile station) measurements, the long code phase information could not be obtained from the signal at the RS-232 port (from code domain power measurement or composite EVM measurement).
- 10872 Cannot correlate to input signal
Cannot correlate to the input signal and no active channel is found. (from composite EVM measurement) An active channel must meet the default threshold criteria that it is within 20 dB of the highest power code channel. The threshold can be changed using the active set threshold function in the Meas Setup menu.

10901 to 10925: NADC Error Messages (Option BAE) An error number in this range indicates the instrument has detected an error relating to the NADC personality.

- 10902 Sync word not found
In an EVM measurement, the sync word is not found and the synchronization cannot be established when **Sync Word** is selected in the **Burst Sync** menu.
- 10904 Valid NADC burst not found
A valid NADC burst is not found when the **Device** is MS.
- 10906 Signal too noisy
The valid EVM measurement cannot be performed, because the input signal is too noisy.
- 10908 Burst Delay out of limit for EVM (2 ms)
In an EVM measurement, the **Burst Delay** value must be less than 2 ms.

10926 to 10950: PDC Error Messages (Option BAE) An error number in this range indicates the instrument has detected an error relating to the PDC personality.

- 10926 Sync word not found
In an EVM measurement, the sync word is not found and the synchronization cannot be established when **Sync Word** is selected in the **Burst Sync** menu.
- 10928 Valid PDC burst not found
A valid PDC burst is not found when the **Device** is MS.
- 10930 Signal too noisy
The valid EVM measurement cannot be performed, because the input signal is too noisy.
- 10932 Burst Delay out of limit for EVM (2 ms)
In an EVM measurement, the **Burst Delay** value must be less than 2 ms.

10951 to 10975: cdmaOne Error Messages (Option BAC) An error number in this range indicates the instrument has detected an error relating to the cdmaOne personality.

- 10952 Signal exceeds maximum allowable power
- 10954 Input overload
Excessive input power has been detected which will cause the ADC to clip the signal. Reduce the signal level, change the attenuator/max total power setting (under **Input** menu), or press **Restart** if the **RF Input Range** is **Auto**.
- 10956 Channel center frequency outside device's transmit band.

- 10960 No power at carrier frequency
No power was detected as a CW or a modulated signal.
- 10962 Cannot correlate to input signal
A correlation failure with the pilot CDMA channel occurred during synchronous demodulation.

10976 to 11000: Phase Noise Error Messages (Option 226) An error number in this range indicates the instrument has detected an error relating to the Phase Noise personality.

- 10976 CMD ERR, <name of offending command>
When a command or command argument is not recognized by the parser a command error is generated.
- 10977 PARAMETER ERROR, <name of offending parameter>
When the “GRAT” or “ANNOT” 8566 series commands are used with arguments other than ON, OFF, 1 or 0.
- 10978 INVALID ITEM, <offending item>
The invalid item message appears when a value that is not part of the commands list of enumerated arguments is entered.
- 10979 INVALID SAVE REG, <invalid register>
When the RCLS or RC commands are used to recall a state register that wasn’t previously saved with the SAVES or SV commands.
- 10980 INVALID TRACE, <trace>
When the argument to a trace command is not part of the predefined trace enumeration (TRA, TRB or TRC).
- 10981 CMD NOT SUPPORTED, <command>
Command not supported errors are generated when a valid 8566 command that is not supported by Chameleon is executed.
- 10982 LOG FILE FULL, CLEAR FOR FURTHER ERROR LOGGING
- 10983 LOG FILE CLEARED

12000 to 12999: Noise Figure Error Messages (Option 219) An error number in this range indicates the instrument has detected an error relating to the Noise Figure personality.

- 12116 Two entries already exist at frequency.
When specifying limit line points, if there are more than two points at the same frequency, the new limit point is discarded and the existing limit is used.
- 12219 Command not valid in this mode.
Indicates that the command sent from the Remote interface does not apply for this DLP.
- 12303 User cal invalidated
The existing user cal has been invalidated because of one of the following reasons:
- Meas mode changed
 - Freq outside cal range
 - Fixed LO changed
 - Sideband changed
- 12304 Alignment Failed
Calibration failed because an error was encountered at some point during the calibration (for example gain < 0)
- 12305 Mode Setup Error
A mode setup error occurred because of one of the following:
- System input frequency out of range
 - External LO frequency out of range
 - Stop freq must be less than fixed LO freq
 - Start freq must be greater than start IF freq
 - LO – Stop freq must be \geq min system input freq
 - Start freq must be greater than fixed LO freq
 - Stop IF freq must be less than fixed LO freq
 - Start – LO freq must be \geq min system input freq
 - Stop freq must be less than stop RF freq
 - Start freq must be greater than start RF freq
- 12307 Required Input attenuation not calibrated
Corrected measurements have been requested and the required RF front-end setting of x dB has not been calibrated.
- 12308 Invalid frequency list for measurement mode
A frequency within the frequency list cannot be used to make a measurement in the current mode.
- 12309 No entries in frequency list
A measurement was attempted with List frequency mode or a SCPI query of the frequency list table was made and the frequency list table is empty.

- 12310 No entries in ENR table
A measurement was attempted or a SCPI query of an ENR table was made and there were no entries in the relevant ENR table (Common, Meas or Cal).
- 12311 No entries in Limit Line table
An attempt is made to either display or test against a limit line table which has no entries.
- 12312 RF re-range required: Meas Restarted.
During a continuous measurement, a change of RF front-end attenuation was required. To do this the measurement needs to be restarted.
- 12313 IF over range req. RF re-range: Meas Restarted.
During a continuous measurement, an IF section over range condition occurred, requiring a change of RF front-end attenuation. To do this, the measurement needs to be restarted.
- 12314 No entries in loss table
A measurement is attempted or a SCPI query of a before or after loss table is made and there are no entries in the relevant loss table
- 12316 T hot must be greater than T cold
A spot T hot has been specified which is not greater than T cold.
- 12603 Illegal MSDOS name given
An invalid filename has been specified. Use filenames with a maximum of 8 characters (letters and digits only) and use a 3 character extension. Note that lowercase and uppercase are perceived as the same.
- 12604 File already exists
Attempt to store a file that already exists. Delete or rename the old file and try again
- 12605 Media is protected
A store was attempted to a write-protected device.
- 12606 Media is not writable
A store was attempted to a read-only device.
- 12612 File does not exist
The file you were trying to recall could not be found.
- 12762 Incorrect filename, allowable extension CSV
Attempt to load/store table data with an incorrect extension.

- 12768 Failed to load ENR data
A problem occurred when trying to load or store table data.
- 12769 Failed to store ENR data
A problem occurred when trying to load or store table data.
- 12770 Incorrect filename, allowable extension ENR
Attempted to load/store table data with an incorrect extension.
- 12771 Failed to load Frequency List
A problem occurred when trying to load or store table data.
- 12772 Failed to store Frequency List
Attempt to load/store table data with an incorrect extension.
- 12773 Incorrect filename, allowable extension LST
Attempt to load/store table data with an incorrect extension.
- 12774 Failed to load Limit line
Attempt to load/store table data with an incorrect extension.
- 12775 Failed to store Limit line
Attempt to load/store table data with an incorrect extension.
- 12776 Incorrect filename, allowable extensions LIM
Attempt to load/store table data with an incorrect extension.
- 12778 Failed to store Trace
A problem occurred when trying to load or store table data.
- 12779 Failed to load Loss data
A problem occurred when trying to load or store table data.
- 12780 Failed to store Loss data
A problem occurred when trying to load or store table data.
- 12781 Incorrect filename, allowable extension LOS
Attempt to load/store table data with an incorrect extension.
- 12995 Noise Figure DLP requires Noise Source Control Hardware
You have attempted to initiate the Noise Figure mode with the Noise Source Control hardware installed in your instrument. You must install the Noise Source Control hardware before running the Noise Figure mode.
- 13214 Frequency Hopping enabled, waiting for valid burst
The demodulated burst type has not been found in the originally demodulated slot location within the frame.

13001 to 13100: 1xEV-DO Error Messages (Option 204) An error number in this range indicates the instrument has detected an error relating to the 1xEV personality.

13024 Signal too noisy

13026 Input power too low

The instrument only identifies a channel as active if it meets the default threshold criteria that it is within 20 dB of the highest power code channel. The threshold can be changed using the Active Set Threshold function in the Meas Setup menu.

13070 Cannot correlate to input signal

Cannot correlate to the input signal and no active channel is found. (from composite EVM measurement) An active channel must meet the default threshold criteria that it is within 20 dB of the highest power code channel. The threshold can be changed using the active set threshold function in the Meas Setup menu.

13074 Valid 1xEV burst not found

In a 1xEV measurement, data was acquired but a 1xEV burst was not found, with the timeslot mode disabled.

13101 to 13200: Flexible Digital Modulation Analysis Error Messages (Option 241) An error number in this range indicates the instrument has detected an error relating to the Flexible Digital Modulation Analysis personality.

13102 Valid signal not found

The input signal cannot be demodulated because of inappropriate parameter settings or incorrect signal

13104 Valid burst not found

The burst signal cannot be detected because of inappropriate parameter settings or incorrect signal.

13106 Sync word not found

The sync word cannot be detected because of inappropriate parameter settings or incorrect signal.

13108 Points/Symbol changed to an even number because of demod format

Offset QPSK allows only even values for points/symbol. The demod format was changed to OQPSK while the points/symbol was set to an odd value. Therefore, the points/symbol was re-set to an even number.

- 13110 Sync Pattern includes non-hex characters
The sync pattern should only consist of hex characters. Invalid characters are converted to 0.
- 13112 Sync Word Length changed to new upper limit
The upper limit of Sync word bits is 128. If the code word length (sync word length) exceeds this value, then the sync word length is cut off. This warning may happen only when the demod format is changed.
- 13114 Sync offset value not valid
The sync offset value is too far off from a value that would be reasonable to measure valid portion of data. So the measurement gives up trying to apply the offset value.
- 13116 Search Length is clipped to the upper value according the dependency of IF Band Width
Search length upper limits:
IF Band Width \leq 1 MHz, Limit = 0.1sec
1MHz $<$ IF Band Width \leq 10MHz, Limit = 0.05sec
10MHz $<$ IF Band Width \leq 20MHz, Limit = 0.025sec
20MHz $<$ IF Band Width \leq 40MHz, Limit = 0.013sec
40MHz $<$ IF Band Width, Limit = 0.007sec
- 13118 Search Length is clipped to the lower value as allowed by current IF Band Width.
Search length lower limits:
IF Band Width \leq 10MHz, Limit = 0.001sec;
10MHz $<$ IF Band Width Limit = 0.1usec
- 13120 Symbol Rate is clipped to its limit because of IF Path change.
Upper limit of Symbol Rate is 10 MHz when IF Path is Narrow.
- 13122 IF BW is clipped to its limit because of IF Path change.
Limit of IF BW depends on IF Path selection. If the value exceeds the limit, it is clipped to the limit. This message will not appear when IF BW is set to AUTO.
- 13124 Meas Interval is clipped to its upper limit because of points/symbol change.
Upper limit of Meas Interval depends on points/symbol setting.

13201 to 13300: Stimulus-Response Measurements Error Messages (Option 215)

An error number in this range indicates the instrument has detected an error relating to the Stimulus Response measurement personality.

- 13226 Connection could not be established with specified IP Address.
A communication connection could not be established at the specified IP Address. Check that the IP address entered is correct and that the signal generator and PSA are both connected to the LAN or connected to one another using a LAN cross over cable.
- 13227 Freq range of ext src exceeded, PSA setting adjustments required.
The calculated external source start or stop frequency exceeds the frequency range of the external source. You need to adjust the PSA settings so that the required source frequency is within it's available range. You may need to adjust the PSA start frequency, the PSA stop frequency, the harmonic number (if on) and/or the frequency offset (if on). The sweep will start again once the required frequency range is in the range available to the source. See the Option 215 documentation for more information about making these settings adjustments.
- 13228 Unable to store reference trace.
Unable to copy the data from trace 1 to trace 3. There is no data in trace 1.
- 13230 Hardware upgrade required. Option 215 disabled.
Option 215 requires the gated sweep hardware. It has not been detected, so an update is required. You should contact the local sales engineer and order E444xAU Option 426.
- 13231 Freq band crossing not supported by Option 215
Option 215 does not support sweeping across a spectrum analyzer hardware frequency band edge. For detailed frequency band information, refer to the "Getting Started" information in the Option 215 guide.
- 13232 Video bandwidth fixed at 50MHz by Option 215
Option 215 forces the video bandwidth to be set to 50MHz while the external source control state is set to ON

Instrument Messages Without Numbers

Error Messages Without Numbers

- Error** Attempt to change signal data failed.
 EMC message, NOT USED
- Error** Awaiting valid signal.
 This indicates that software enhanced triggering is ON and 5 successive failures have been detected within a demod measurement
- Error** Unable to retrieve signal (remote).
 EMC message NOT USED
- Error** Unable to uninstall personality, file not deletable.
 This message occurs when you try to delete a personality which has been marked as non-deletable. The personality is marked non-deletable at the factory. Get in touch with your nearest service center for further assistance.

Informational Messages

These messages simply provide information; you are not required to do anything. Information in brackets (such as <directoryname>), is a previously-provided input.

Informational messages appear at the bottom of the screen in the status line.

- Informational** <directoryname> directory deleted
 The directory indicated has been successfully deleted.
- Informational** <name1> directory renamed to <name2>
 <directoryname1> directory renamed to <directoryname2>
 Directory name1 has been successfully renamed to directory name2.
- Informational** <filename> file copied
 The filename indicated has been successfully copied.
- Informational** <filename> file deleted
 The filename indicated has been successfully deleted.
- Informational** <filename> file loaded
 The filename indicated has been successfully loaded.
- Informational** <filename> file saved
 The filename indicated has been successfully saved.

- Informational** <filename> too many data entries
- This message may appear when loading data from a limit line or amplitude correction file. The [DATA] section of such a file can contain at most 200 lines of data. This message is displayed if that limit is exceeded.
- Informational** <filename1> file renamed to <filename2>
- <name1> file renamed to <name2>
- File name1 has been successfully renamed to file name2.
- Informational** Atten auto set to 15 dB
- Indicates that an input signal has been detected which is of sufficient level to damage the input circuitry and the input attenuator has been automatically set to 15 dB. If the signal level is reduced, the attenuator will stay at 15 dB. This overload protection occurs at an input power level of 13 dBm (68 dBmV for Option 1DP) \pm 7 dB when the input attenuation is auto coupled and set to <15 dB. To return to the original measurement setup, reduce the input signal level and press **Amplitude**. Then press **Attenuation (Auto)**.
- Overload protection is only available in the Agilent Technologies E4401B and E4411B.
- Informational** Auto ranging...
- Displayed during autoranging.
- Informational** B7D and/or B7E not found. Code Domain not available.
- Digital Signal Processing and Fast Analog to Digital Converter (Option B7D) and/or RF Communications Hardware (Option B7E) are not installed options on your analyzer. Code domain is therefore not available.
- Informational** B7D and/or B7E not found. Mod Acc not available.
- Digital Signal Processing and Fast Analog to Digital Converter (B7D) and/or RF Communications Hardware (B7E) are not installed options on your analyzer. Modulation accuracy is therefore not available.
- Informational** Carrier Not Present.
- A carrier signal/burst is expected at the analyzer input. This signal cannot be found; however, the measurement will still run. Check input signal connection.
- Informational** Channel frequency outside device's transmit band.
- Reset channel number or frequency.
- Informational** Default spur table values loaded.
- No spur table has been previously saved when the Out-of-Band Spurious measurement begins. Press **Meas Setup, Edit Table** to enter the frequency ranges of interest and press **Save Table** to save that information. This saved table will be loaded the next time the measurement is run.

- Informational** Device = Mobile. Code Domain not available.
Code Domain measurement is grayed out when the device is set to mobile under the **Mode Setup** front-panel key. Code Domain measurement is only accessible when the device is set to base and RF Communications Hardware (Option B7E) or Enhanced Memory Upgrade (Option B72) are installed.
- Informational** Directory already exists
Each directory and file must have a unique name. The directory name you have entered is currently being used on the selected drive. You may either enter a new name or rename the directory currently existent.
- Informational** Device = Mobile. Mod Acc not available.
Modulation accuracy measurement is grayed out when the device is set to mobile under **Mode Setup**, front-panel key. Modulation accuracy is only accessible when the device is set to base and RF Communications Hardware (Option B7E) or Enhanced Memory Upgrade (Option B72) are installed.
- Informational** Directory already exists
Each directory and file must have a unique name. The directory name you have entered is currently being used on the selected drive. You may either enter a new name or rename the directory currently existent. Refer to “File Menu Functions” in the Agilent *ESA Spectrum Analyzer User’s Guide*.
- Informational** ENR table will be extrapolated
One or more calibration or measurement frequency points exceeds the currently loaded Cal or Meas ENR Table frequency ranges. The corresponding ENR tables lowest frequency ENR value will be re-used for frequencies less than the table range, and the highest frequency ENR value will be re-used for frequencies greater than the table range.
- Informational** HW Average
For Option 122 only. If frame triggering is on, this message shows if you turn on the hardware time averaging.
- Informational** Entire trace is below the threshold level.
The measurement cannot operate properly because the trace has fallen completely below the threshold level. Change the threshold level to view signal.
- Informational** Invalid format: CSV files are not supported by this measurement.
When utilizing the Phase Noise Personality: Option 226, the *.CSV file format is not available.
- Informational** Invalid EDGE burst timing.
The burst has manually been positioned off the display.

- Informational** Measurement halted. Press a measurement key to continue.
This error occurs after you choose **Cancel** to refrain from setting the attenuator to 0 dB during the Receive Channel Power and Receive Spur measurements.
- Informational** No Fast ADC hardware installed. Meas unavailable.
The analyzer cannot use sweep times of less than 5 milliseconds when Option B7D or Option AYX is not installed. Therefore the measurement will not be executed.
- Informational** Not enough frequency range to measure harmonics for channel.
Selected harmonics are above the frequency range of the analyzer.
- Informational** One or more harmonics beyond freq limit: number decreased.
The highest harmonic was beyond the frequency limit of the analyzer, so the number of measured harmonics was decreased.
- Informational** Option activated
This message is displayed after entering the selected option's License Key.
- Informational** Please set RF input range (INPUT menu) to manual first.
In order to manually set the reference level and/or the attenuation under the **Amplitude** front-panel key, the RF Input Range menu under the **Input** front-panel key must be set to **Man** (manual).
- Informational** Shutdown in process.
The analyzer is responding to the **Standby** key selection, and is executing the shutdown procedure.
- Informational** Table loaded successfully.
When the **Load Table** key was pressed on the second page of the edit table form while in the out-of-band spurious measurement, the file was present. The information has been loaded into the measurement where it may be edited again. This message will also appear when the out-of-band spurious measurement is opened if a spur table has been previously saved.
- Informational** Table saved successfully.
This message appears after you press the **Save Table** key on the second page of the edit table for the out-of-band spurious measurement. It indicates that the current spur table has been written successfully to disk and is available to be loaded by means of the **Load Table** key.
- Informational** The calibration data is invalid, and has been cleared.
A parameter has changed that affects calibration. Therefore the calibration data has been reset, and for best results recalibration is recommended.

- Informational** The file containing the list of cable types has been updated.
The file update was successful.
- Informational** This measurement does not support the *.CSV file format.
When utilizing the Phase Noise Personality: Option 226, *.CSV (comma separated values) file format is not available.
- Informational** This operation requires a measurement to be active.
The analyzer cannot perform this operation, because it requires a measurement to be running and no measurement is running.
- Informational** Tracking Peak Needed.
This message is displayed when there has been a change in Resolution Bandwidth, Span, or Alignment since the previous Tracking Peak.
The message does not apply to the E4401B or E4411B Spectrum Analyzer.
- Informational** Use trigger delay to align bit p0 center on marker.
Tells you where to manually align P0.
- Informational** WARNING: You are about to delete all of the contents of directory "x:\xxxxx\". Press Delete Now again to proceed or any other key to abort.

WARNING: You are about to delete all of the contents of directory xxxxxx. Press Delete Now again to proceed or any other key to abort.

If you select a directory or subdirectory to delete, this popup message is displayed when you press **Delete Now**. (xxxxx in the message is the full path and directory name).
- Informational** Waiting for end of data acquisition to access floppy disk
- Informational** Volume <name> formatted
The indicated disk has been successfully formatted.
- Informational** Time resolution is low, reduce Meas Time or increase Trace Points
Changing either Meas Time or Trace Points has increased the burst to mask uncertainty greater than 0.4 symbol. You should lower the Meas Time or increase Trace Points to reduce this uncertainty.

Status Messages

These messages indicate conditions that can cause the display of incorrect data. The name of the corresponding status bit appears in parenthesis. Some messages display *only* the status bit (as noted).

Status messages appear in the upper right portion of the screen grid.

Status * (Invalid Data)

Data on the screen may not match the screen annotation. For example, while analyzer settings are changing or when any trace is in view mode.

Status 50 MHz Osc Unlevel (50 MHz Osc Unleveled)

The internal 50 MHz amplitude reference source has become unlevelled. This condition must be corrected before a valid alignment can be performed.

Status (ADC Align Failure) *status bit only, no message*

The alignment routine was unable to align the analog-to-digital converter (ADC).

Status Align Now All Needed (Align Needed)

The instrument requires complete alignment. Press **System, Alignments, Align Now, All**. On all Agilent Technologies ESA spectrum analyzer models except Agilent Technologies E4401B and E4411B, you must connect the **AMPTD REF OUT** to the **INPUT** with the appropriate cable to perform this alignment. *For Agilent Technologies E4401B and E4411B only:* disconnect any signals from the **INPUT** prior to performing this procedure. If this message recurs, load defaults (**System, Alignments, Load Defaults**) and then perform **Alignment Now, All**.

Status Align Now RF Needed (Align Now RF Needed)

The instrument requires RF alignment. Press **System, Alignments, Align Now, RF (EXT Cable)**. On all Agilent Technologies ESA spectrum analyzer models except Agilent Technologies E4401B and E4411B, you must connect the **AMPTD REF OUT** to the **INPUT** with the appropriate cable to perform this alignment. *For Agilent Technologies E4401B and E4411B only:* disconnect any signals from the **INPUT** prior to performing this procedure.

Status Align RF Skipped (Align RF Skipped)

The RF alignment has been skipped because a 50 MHz signal was detected at the **INPUT**; alignment will resume when the 50 MHz signal is removed. The alignment will not work when there is too much input power at 50 MHz. The instrument may not continue to measure properly. To remove the message, remove the 50 MHz input signal, then perform an **Align Now, RF**. Press **System, Alignments, Align Now, RF**. On all Agilent Technologies ESA spectrum analyzer models except E4401B and E4411B, you must

connect the **AMPTD REF OUT** to the **INPUT** with the appropriate cable to perform this alignment. *For Agilent Technologies E4401B and E4411B only:* disconnect any signals from the **INPUT** prior to performing this procedure.

If this message occurs and you are going to make a measurement near 50 MHz, select **System, Alignments, Auto Align, and All but RF**.

- Status Align RF Skipped, Align signal amplitude too low
- The RF alignment has been skipped because the calibration output power is too low.
- Status DC Coupled
- Indicates the input of the analyzer is DC coupled (**Input/Output, Coupling (DC)**). This setting is necessary when measuring frequencies below 100 kHz on E4402B with Option UKB, E4404B, and E4405B analyzers. For E4407B analyzers with Option UKB, you must set the coupling to DC when measuring below 10 MHz. Take care to limit the input level to 0 Vdc and +30 dBm whenever you are in DC coupled mode.
- Status Demod ON: reduce span for audible detection
- When the Demod function is active and the speaker is turned on, the ratio of the resolution bandwidth to span must be greater than 0.002 to properly demodulate and listen to the resulting audio signal. You must decrease the span to continue the measurement
- Status Ext Ref (*no corresponding status bit*)
- The instrument's frequency reference has been set to **External Reference**. This message will appear even if an external reference is not connected to the instrument. The external reference frequency must also be entered.
- Indicates that the frequency reference is being supplied by an external 10 MHz source.
- Status External LO frequency out of range
- One or more external LO frequencies are out of range. Check that the LO frequency limits are set correctly and check the entered measurement frequencies and measurement mode.
- Status Final IF Overload (IF/ADC Overrange)
- The final IF section has been overloaded. Measurement results may be invalid. Either increase the input attenuation or decrease the input signal level.
- Status First IF Overload (IF/ADC Overrange)
- The first IF section has been overloaded. Measurement results may be invalid. Either increase the input attenuation or decrease the input level.

Status	Flat corr off (no corresponding status bit) Indicates that the flatness corrections have been turned off.
Status	(FM Demod Align Failure) <i>status bit only, no message</i> A failure has occurred during the FM Demod alignment. Measurement results may be invalid.
Status	Freq corr off (no corresponding status bit) Indicates that the frequency corrections have been manually disabled. Press System, Alignments, Freq Correct, (On) to restore.
Status	Freq Count: Reduce Span/RBW ratio The span is too wide for the current resolution bandwidth. Either reduce the span or increase the RBW.
Status	Freq outside cal range The existing user cal has been invalidated because the current measurement frequencies lie partially or wholly outside the range of frequencies used for user-cal.
Status	Frequency Reference Error (Freq Ref Unlocked) The frequency reference lock loop has unlocked or is near an unlock condition. This message can occur when either the internal or external reference is selected. If external reference is selected, assure the frequency of the external reference source exactly matches the entered value displayed on the reference menu key. The frequency reference has been tuned too far off of 10 MHz. This condition may be corrected by cycling power on the analyzer.
Status	(IF Align Failure) <i>status bit only, no message</i> A failure has occurred during the IF alignment. Measurement results may be invalid.
Status	IF Gain fixed The autoranging function of the analyzer has been turned off (Amplitude, More, More, IF Gain (Fixed)). This setting is useful when measuring signals that require fast measurement time, narrow resolution bandwidths (< 1 kHz), and < 70 dB of display range. For more information on this setting, refer to IF Gain key description in the <i>ESA Spectrum Analyzer User's Guide</i> .
Status	IF Overload (IF/ADC Over Range) The IF section has been overloaded. Measurement results may be invalid.

Status	Input is internal (no corresponding status bit) <i>This message applies to the Agilent Technologies E4401B and E4411B only.</i> Indicates the 50 MHz Amptd Ref selection is On . With the 50 MHz amplitude reference on, the input is routed through an internal signal path.
Status	LO - Stop freq must be \geq min system input freq The current measurement mode requires that the stop RF (input to DUT) frequency must be more than the minimum system input frequency away from the fixed LO frequency.
Status	(LO Align Failure) status bit only, no message A failure has occurred during the alignment of the local oscillator (LO). Measurement results may be invalid.
Status	LO Out Unlevel (LO Out Unleveled) Indicates the output of the local oscillator (LO) has become unlevelled. This condition must be corrected to make valid measurements.
Status	LO Unlevel (LO Unleveled) Indicates the internal circuitry of the local oscillator (LO) has become unlevelled. This condition must be corrected to make valid measurements.
Status	LO Unlock (Synth Unlocked) Indicates the phase locked circuitry of the local oscillator (LO) has become unlocked. This condition must be corrected to make valid measurements.
Status	Log Corr Off (no corresponding status bit) The log amplifier corrections have been turned off.
Status	Marker Count:Widen Res BW The ratio of the resolution bandwidth to span must be greater than 0.002 for the marker count function to work properly. Increase the resolution bandwidth or decrease the span to continue the measurement.
Status	Meas Uncal (Oversweep) The measurement is uncalibrated, usually due to sweeping a narrow RBW filter too quickly. Check the sweep time, span, and bandwidth settings, or press Auto Couple .
Status	Measurement outside Internal Preamp range The Internal Preamp is currently turned on, but the measurement is being performed outside the range of the preamp.

Status Measurement partially outside Internal Preamp range

The Internal Preamp is currently turned on, and the measurement range is being performed partly within and partly outside this range. It is recommended that you turn the preamp off to ensure consistent results across the entire measurement.

Status Overload: Reduce Signal and press <ESC> (Input Overload Tripped)

This message applies to the Agilent Technologies E4401B and E4411B only. A signal has been applied to the input connector that caused the overload protection circuitry to engage. The input signal must be reduced. After the signal is reduced, press **ESC** to reset the overload detector so that you can continue using the analyzer.

CAUTION Exposing the analyzer to high levels of input power over a prolonged period of time can damage the internal circuitry.

Status Peaking Signal (no corresponding status bit)

The instrument is executing a tracking generator peak.

Status Preferred resolution bandwidth not available.

The calculated required resolution bandwidth for this measurement is not available.

Status (RF Align Failure) *status bit only, no message*

A failure has occurred during the alignment of the RF section. Measurement results may be invalid.

Status Signal Ident On, Amptd Uncal (Signal Ident On)

Indicates that the amplitude measurement could be uncalibrated because the signal identification feature is on.

Status Signal level is low.

Indicates the signal can be correlated, however the level is below that specified to ensure accurate measurement results.

Status Source LO Unlevel (Source LO Unleveled)

The internal circuitry of the local oscillator (LO) in the tracking generator has become unlevelled. This condition must be corrected to make valid measurements.

Status Source LO Unlock (Source Synth Unlocked)

The phase-locked circuitry of the local oscillator (LO) in the tracking generator has become unlocked. This condition must be corrected to make valid measurements.

Status	Source Unlevel (Source Unleveled) Indicates the source power is set higher or lower than the analyzer can provide, the frequency span extends beyond the specified frequency range of the tracking generator, or the calibration data for the source is incorrect.
Status	Start freq must be greater than fixed LO freq The current measurement mode requires that the start frequency must be greater than the fixed LO frequency.
Status	Start freq must be greater than start RF freq The current measurement mode requires that the start IF (output to DUT) frequency must be greater than the start RF (input to DUT) frequency.
Status	Start - LO freq must be \geq min system input freq The current measurement mode requires that the start RF (input to DUT) frequency must be more than the minimum system input frequency away from the fixed LO frequency.
Status	Stop freq must be less than fixed LO freq The current measurement mode requires that the stop frequency must be less than the fixed LO frequency.
Status	Stop freq must be less than stop RF freq The current measurement mode requires that the stop IF (output to DUT) frequency must be less than the stop RF (input to DUT) frequency.
Status	Stop IF freq must be less than fixed LO freq The current measurement mode requires that the stop IF (output to DUT) frequency must be less than the fixed LO frequency.
Status	System, Alignments, Align All Now Needed (Align Needed) This message occurs only when Auto Align is set to Alert . The instrument requires an Align All Now . Restore the alignment by pressing System, Alignments, Align All Now .
Status	System input frequency out of range One or more system input frequencies are out of range. If using a frequency list, check that all entries are valid for current measurement mode.
Status	System Alignments, Align Now, All Required Internal alignment correction data has been lost. Press System, Alignments, Align Now, All to clear this message from the display.
Status	(TG Align Failure) status bit only, no message A failure has occurred during the tracking generator (TG) alignment.

Status Video shift off (no corresponding status bit)
Indicates the video shift has been manually disabled; this will impair readings.

Annunciator Bar Messages

Annunciator Align
This message appears in the left side of the annunciator bar in red. When this message appears it indicates that there is one or more condition that has affected the alignment. For the possible conditions and suggested resolutions, refer to [Align Now All Needed \(Align Needed\) on page 89](#), [Align Now RF Needed \(Align Now RF Needed\) on page 89](#), [Align RF Skipped \(Align RF Skipped\) on page 89](#), and [System Alignments, Align Now, All Required on page 94](#).

Annunciator Ext Ref
This message appears in the right side of the annunciator bar in green. When this message appears it indicates that there is one or more condition that affects the reference source. For the possible conditions and suggested resolutions, refer to [Ext Ref on page 90](#).

Annunciator FreqRefUnlock
This message appears in the left side of the annunciator bar in red. When this message appears it indicates that there is one or more condition that results in a frequency reference error. For the possible conditions and suggested resolutions, refer to [Frequency Reference Error \(Freq Ref Unlocked\) on page 91](#).

Annunciator Overload
This message appears in the left side of the annunciator bar in red. When this message appears it indicates that there is one or more condition that causes a system overload. For the possible conditions and suggested resolutions, refer to [IF Overload on page 91](#) and the Status [overload on page 93](#).

Annunciator Uncal
This message appears in the left side of the annunciator bar in red. When this message appears it indicates that there is one or more condition that results in uncalibrated results. For the possible conditions and suggested resolutions, refer to [Meas Uncal \(Oversweep\) on page 92](#).

Annunciator Unlevel
This message appears in the left side of the annunciator bar in red. When this message appears it indicates that there is one or more condition that affects the leveling of an internal signal, such as the local oscillator (LO) or the tracking generator (source). For the possible conditions and suggested

resolutions, refer to [50 MHz Osc Unlevel \(50 MHz Osc Unleveled\)](#) on page 89, [LO Out Unlevel \(LO Out Unleveled\)](#) on page 92, [Source LO Unlevel \(Source LO Unleveled\)](#) on page 93, and [Source Unlevel \(Source Unleveled\)](#) on page 94.

Annunciator Unlock

This message appears in the left side of the annunciator bar in red. When this message appears it indicates that there is one or more condition that affects locking one or more of the local oscillators (LOs). For the possible conditions and suggested resolutions, refer to [LO Unlock \(Synth Unlocked\)](#) on page 92.

2 Functional Tests

What You Will Find in This Chapter

This chapter describes the functional tests and provides information on how to perform them.

What Are the Functional Tests?

Functional tests are tests of various instrument parameters that give a high degree of confidence that the analyzer is operating correctly. They are recommended as a check of analyzer operation for incoming inspection or after a repair. Measurement uncertainty analysis is not available for functional tests, and the analyzer is checked against limits that are wider than the published specifications. The functional tests are designed to test an analyzer operating within the temperature range defined by the analyzer specifications using a minimum set of test equipment. If a test does not pass, performance tests must be run to confirm a problem exists.

Functional Test Versus Performance Verification

Functional tests use a minimum set of test equipment to check a much smaller range of parameters (and a limited number of data points for each parameter) than do performance verification tests. Functional tests use limits that are wider than the published specifications; measurement uncertainty analysis is *not* available for functional tests.

NOTE If a functional test does not pass, you must run performance verification tests to confirm that a problem exists.

Performance verification tests span a wide range of instrument parameters and provide the highest level of confidence that the instrument conforms to published specifications. These tests can be time consuming and require extensive test equipment.

This chapter includes the following:

- “Before Performing a Functional Test” on page 100 (what to do first).
- “Test Equipment” on page 101 (a list of the equipment required for *all* of the tests).
- PSA Functional Tests (*PSA only*):
 - “Amplitude Accuracy at 50 MHz” on page 106
 - “Displayed Average Noise Level (DANL)” on page 111
 - “Frequency Readout Accuracy” on page 113
 - “Frequency Response (Flatness)” on page 115
 - “Amplitude Linearity” on page 119
 - “Second Harmonic Distortion (SHD)” on page 122
- ESA Functional Tests (*ESA only*):
 - “Displayed Average Noise Level” on page 126

- “Frequency Readout Accuracy” on page 142
- “Marker Count Accuracy” on page 145
- “Frequency Response (Flatness)” on page 146
- “Reference Level Accuracy” on page 151
- “Resolution Bandwidth Switching Uncertainty” on page 156
- “Scale Fidelity” on page 159
- “Second Harmonic Spurious Responses” on page 162
- “Tracking Generator Level Flatness: Models E4401B and E4411B, Options 1DN and 1DQ” on page 165
- “Tracking Generator Level Flatness: E4402B, E4403B, E4404B, E4405B, E4407B and E4408B, Option 1DN” on page 168

Each functional test includes:

- Test limits (pass/fail criteria)
- A description of the test
- The equipment required for the test
- A figure showing how to connect the equipment
- Step-by-step instructions
- One or more tables in which to record the measurement results

Before Performing a Functional Test

1. Ensure that you have the proper test equipment.
2. Switch on the unit under test (UUT) and let it warm up (in accordance with warm-up requirements in the instrument specifications).
3. Allow sufficient warm-up time for the required test equipment (refer to individual instrument documentation for warm-up specifications).
4. Ensure that the analyzer's frequency reference is set to Internal:
 - a. Press the **System, Reference** keys.
 - b. If the **Freq Ref** softkey does *not* have **Int** underlined, press the **Freq Ref** softkey until it is underlined.
5. Following instrument warm-up, perform the auto align routine:
Press **System, Alignments, Align All Now**.

NOTE Functional test accuracy depends on the precision of the test equipment used. Ensure that all of the test equipment is calibrated before running a functional test.

TEST EQUIPMENT

The table below summarizes the test equipment needed to perform all of the functional tests. Alternate equipment model numbers are given in case the recommended equipment is not available.

If neither the recommended nor the alternative test equipment are available, substitute equipment that meets or exceeds the critical specifications listed.

Analyzer	Item	Critical Specifications	Recommended Agilent Model	Alternate Agilent Model
Adapters				
PSA ESA	3.5 mm (f) to 3.5mm (f) (connector saver for 83630B)		5061-5311	
PSA ESA	3.5 mm (f) to N (f)		1250-1745	
PSA	2.4 mm (f) to 3.5 mm (m)	E4446A, E4448A only	11901D	
PSA	BNC (f) to SMA (m)		1250-1200	
PSA	BNC (m) to SMA (f)		1250-1700	
ESA	BNC (m) to SMA (f)		1250-2015	
PSA ESA	Type N (f) to BNC (m)		1250-1534	
PSA	Type N (f) to N (f)		1250-1472	1250-0777
PSA ESA	Type N (m) to 3.5 mm (f)		1250-1744	
PSA ESA	Type N (m) to 3.5 mm (m)		1250-1743	
PSA	Type N (m) to BNC (f)		1250-1476	
ESA	Type N (m) to BNC (f)		1250-0780	
Attenuators				
PSA	10 dB Step Attenuator	Range: 0 to 60 dB	355D	
PSA	20 dB Fixed Attenuator	Accuracy: < 0.5 dB	8491A	8491B
Cables				
PSA ESA	APC 3.5 mm (1 meter)		8120-4921	
ESA	APC 3.5 mm	E4407B and E4408B only	11500E	

Functional Tests
Test Equipment

Analyzer	Item	Critical Specifications	Recommended Agilent Model	Alternate Agilent Model
ESA	APC 3.5 mm		11500D	
ESA	Type-N, 152-cm (60-in)		11500D	
ESA	APC 3.5 mm	E4407B and E4408B only	11500E	
PSA ESA	Cable, BNC (2 required)	120 cm (48 in.) BNC cable	10503A	
Signal Source				
PSA	Synthesized Sweeper	<i>Frequency: 10 MHz to 26.5 GHz</i> <i>Harmonic level: < -40 dBc</i> <i>Amplitude range: 10 to -20 dBm</i> <i>Frequency Accuracy: 0.02%</i>	83630B	83640B, 83650B
PSA	Synthesized Sweeper	<i>Frequency: 10 MHz to 50 GHz</i> <i>Harmonic level: < -40 dBc</i> <i>Amplitude range: 10 to -20 dBm</i> <i>Frequency Accuracy: 0.02%</i> E4446A, E4448A only	83650B	
ESA	Synthesized Sweeper	<i>Frequency: 10 MHz to 26.5 GHz</i> <i>Harmonic level: < -40 dBc</i> <i>Amplitude range: 10 to -20 dBm</i> <i>Frequency Accuracy: 0.02%</i>	83640A/B	836XX series
Miscellaneous Equipment				
PSA ESA	Filter, 50 MHz Low Pass	<i>Cutoff Frequency: 50 MHz</i> <i>Rejection at 65 MHz: > 40 dB</i> <i>Rejection at 75 MHz: > 60 dB</i> <i>Rejection at 80 MHz: > 60 dB</i>	0955-0306	
PSA	Power Meter	<i>Power Reference Accuracy: ±1.2%</i> Compatible with power sensor	E4418B	E4419B
ESA	Power Meter	<i>Power Reference Accuracy: ±1.2%</i> Compatible with power sensor	438A	
PSA ESA	Power Sensor	<i>Frequency Range: 50 MHz to 26.5 GHz</i> <i>Amplitude Range: -25 to 10 dBm</i>	8485A	E4413A
ESA	Power Sensor	<i>Frequency Range: 100 kHz to 3.0 GHz</i> <i>Amplitude Range: -25 to 10 dBm</i>	8485A	E4413A
PSA	Power Sensor	<i>Frequency Range: 50 MHz to 50 GHz</i> E4446A, E4448A only	8487D	
PSA ESA	Power Splitter, 3.5 mm	<i>Nominal Insertion Loss: 6 dB</i> <i>Tracking Between Ports: < 0.25 dB</i>	11667B	11667A

Analyz er	Item	Critical Specifications	Recommended Agilent Model	Alternate Agilent Model
PSA	Power Splitter	<i>Frequency Range: 50 MHz to 50 GHz</i> <i>Tracking between ports: < 0.25 dB</i> E4446A, E4448A only	11667C	
ESA	Power Splitter, 3.5 mm	<i>Nominal Insertion Loss: 6 dB</i> <i>Tracking Between Ports: < 0.25 dB</i> E4401B, E4402B, E4403B, E4404B, E4405B and E4411B only	11667A	
ESA	Power Splitter, 3.5 mm	<i>Nominal Insertion Loss: 6 dB</i> <i>Tracking Between Ports: < 0.25 dB</i> E4407B and E4408B only	11667B	11667A
PSA	Termination, 50Ω	Type N (m) Connector <i>Frequency: 1 MHz to 4 GHz</i>	909A Option 012	
ESA	Termination, 50Ω	Type N (m) Connector <i>Frequency: 1 MHz to 4 GHz</i>	908A	

3 PSA Functional Tests

Amplitude Accuracy at 50 MHz

Test Limits

Amplitude Accuracy should remain within ± 1.0 dB of the measured source value across the range of source levels and changes in resolution bandwidth. Option 1DS (preamp option) should remain within ± 1.3 dB of measured values.

Test Description

A synthesized sweeper is used as the signal source for the test. The source amplitude is varied using the signal source amplitude control. The resolution bandwidth is also varied on the spectrum analyzer. The source amplitude is measured by the power meter and spectrum analyzer at each setting, and the values compared. The difference between each pair of measurements indicates the amplitude accuracy.

Item	Critical Specifications	Recommended Agilent Model
Adapter	Type-N(m), to 3.5 mm(m)	1250-1743
Adapter	3.5 mm(f) to 3.5 mm(f)	5061-5311
Attenuator, 20 dB	<i>Accuracy:</i> < 0.5 dB	8491A
Cable	APC 3.5 mm, 1 meter	8120-4921
Power Meter	Compatible with power sensor	E4418B
Power Sensor	<i>Amplitude Range:</i> -25 dBm to 10 dBm	8485A
Power Splitter	3.5 mm 6 dB loss	11667B
Synthesized Sweeper	<i>Typical Temperature Stability:</i> 0.01 dBc/°C	83630B

Figure 3-1. Amplitude Accuracy Test Setup

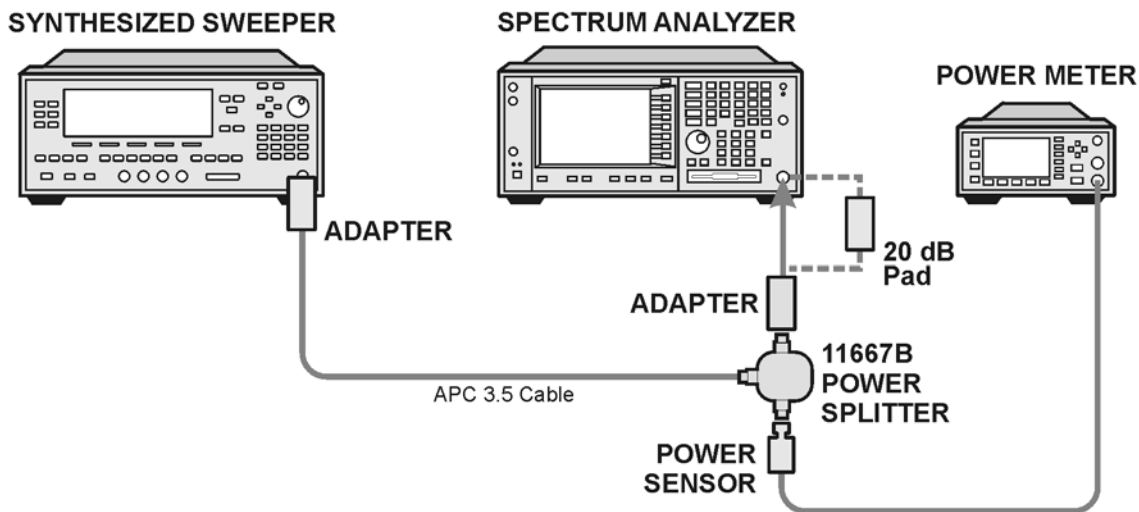

ee81a

Procedure

1. Zero and calibrate the power meter.
2. Configure equipment as shown in [Figure 3-1.](#), with the power splitter connected to the spectrum analyzer input.

CAUTION To minimize stress on the test equipment connections, support the power sensor.

3. If the auto alignment for the analyzer has not been performed within the past 24 hours, press **System, Alignments, Align All Now** to perform the auto alignment routine.
4. Press **Preset** (Factory Preset) on the analyzer.
5. Set up the spectrum analyzer by pressing:

Frequency, 50, MHz
Span, 2, MHz
Input/Output, RF Coupling (DC)
Amplitude, Attenuation, 10, dB
Sweep, Auto Swp Time, Accy

6. Set up the synthesized sweeper by pressing:

CW, 50, MHz
Power Level, -4, dBm
RF (On)

PSA Functional Tests
Amplitude Accuracy at 50 MHz

7. On the spectrum analyzer, press:
BW/Avg, Average (On)
20, Enter
8. Perform the following steps for each row listed in [Table 3-1](#):
 - a. Set the synthesized sweeper amplitude to the value listed in the Nominal Source Amplitude column in [Table 3-1](#).
 - b. Set the Attenuation and Span as listed in each row of the table.
 - c. Record the source amplitude, as measured by the power meter, in the Power Meter Amplitude column of [Table 3-1](#).
 - d. On the spectrum analyzer, press **Restart, Peak Search**.
 - e. Wait for the spectrum analyzer to finish averaging.
 - f. Record the signal amplitude, as measured by the analyzer in the Measured Amplitude column of [Table 3-1](#).
 - g. Calculate the signal amplitude accuracy error using the following equation, and record the results under the Amplitude Accuracy Error column:

$$\text{Amplitude Accuracy Error} = \text{Meas_amp} - \text{Power_meter}$$

Figure 3-2. Amplitude Accuracy Test Setup

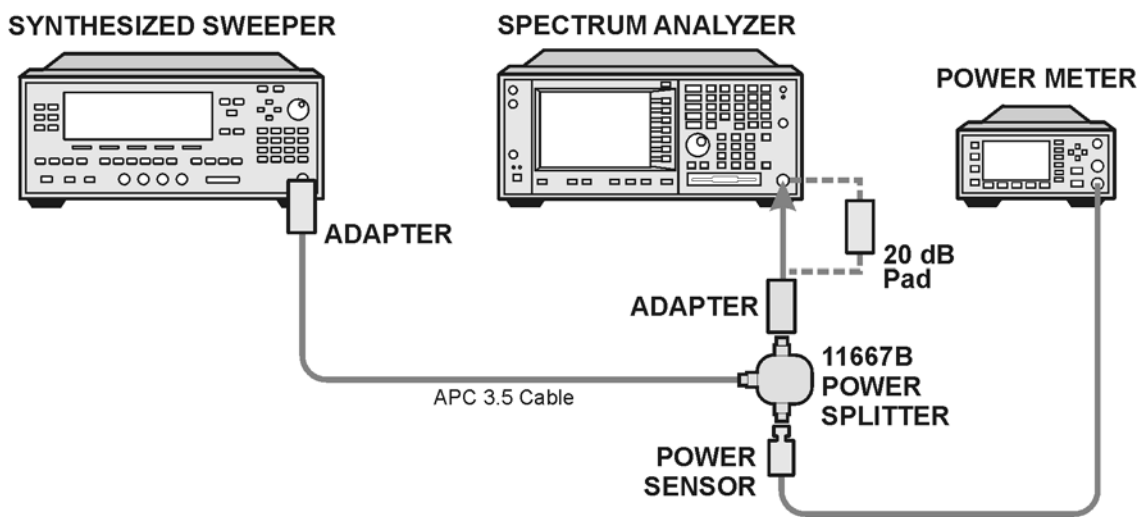

ee81a

Table 3-1 Amplitude Accuracy Results

Nominal Source Amplitude (dBm)	Preamp (Option 1DS)	Attenuation (dB)	Span (MHz)	Measured Amplitude Meas_amp (dBm)	Power Meter Amplitude Power_meter (dBm)	Amplitude Accuracy Error (dB)	Test Limit (dB)
-4	Off	10	2				± 1.0
-9	Off	10	1				± 1.0
-14	Off	10	0.5				± 1.0
-4	Off	20	0.1				± 1.3
-14	Off	20	0.1				± 1.3
-4	Off	30	0.1				± 1.3
-14	Off	30	0.1				± 1.3

Testing Option 1DS (Preamp)

Instruments containing Option 1DS must have the preamp function turned on and tested. In order to enable this function, press **Amplitude, More 1 of 3, Int Preamp (On)**.

Procedure

1. Connect the 20 dB pad between the input of the spectrum analyzer and the power splitter, as shown in [Figure 3-1](#).
2. Set the synthesized sweeper amplitude to the value listed in the Nominal Source Amplitude column in [Table 3-2](#).
3. Assure the spectrum analyzer input attenuation is set to 10 dB.
4. Set the Res BW and Span as listed in [Table 3-2](#).
5. Record the source amplitude, as measured by the power meter, in the Power Meter Amplitude column of [Table 3-2](#).
6. On the spectrum analyzer, press **Restart, Peak Search**.
7. Wait for the analyzer to finish averaging.
8. Record the signal amplitude as measured by the analyzer in the measured amplitude column of [Table 3-2](#).
9. Calculate the signal amplitude accuracy using the following equation:

$$\text{Amplitude Accuracy Error} = \text{Meas_amp} + 20 \text{ dB} - \text{Corrected Power Value}$$

10. Record the results under the Amplitude Accuracy Error column of [Table 3-2](#).

Table 3-2 Amplitude Accuracy Results (Option 1DS)

Nominal Source Amplitude (dBm)	Preamp (Option 1DS)	Res BW (kHz)	Span (kHz)	Measured Amplitude Meas_amp (dBm)	Power Meter Amplitude Power_meter (dBm)	Amplitude Accuracy Error (dB)	Test Limit (dB)
-13	On	1	106				1.2

Displayed Average Noise Level (DANL)

Test Limits (with 0 dB input attenuation)

See [Table 3-3](#) for values.

Test Description

The Displayed Average Noise Level (DANL) of the spectrum analyzer is measured across a 10 kHz frequency span at several center frequencies. The analyzer input is terminated into a 50Ω load. A test is performed to assure the measurement is not performed in the presence of a residual response. The measurement is then averaged, and the result is normalized to a 1 Hz bandwidth.

Item	Critical Specifications (for this test)	Recommended Agilent Model
Termination	50Ω Type-N(m)	909A Option 012

Figure 3-3 DANL Test Setup

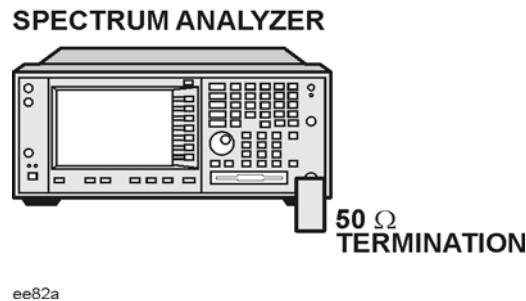

Procedure

1. Configure the equipment as shown in [Figure 3-3](#).
2. Press **Preset** (Factory Preset) on the analyzer.
3. Set up the spectrum analyzer by pressing:

FREQUENCY, Center Freq, 5. MHz
 Input/Output, RF Coupling, DC
 Span, 10 kHz
AMPLITUDE, -70, dBm
 Amplitude, Attenuation, 0, dB
 BW/Avg, 1, kHz
 Video BW, 100 Hz
 Average (On), 20, Enter

PSA Functional Tests
 Displayed Average Noise Level (DANL)

4. Press **Display**, then press the **Display Line** key.
5. Rotate the RPG knob and set the display line at the average amplitude of the displayed noise floor by visual inspection.
6. Confirm that the measurement will be performed on the spectrum analysis noise floor and not on a residual response within the displayed 10 kHz span.

NOTE Ignore the residual response if one appears when taking the measurement.

7. Enter the value of the display line as the Measured Average Noise Level at 5 MHz column in [Table 3-3](#).
8. Normalize the measured value to a 1 Hz BW by adding -30 dB to the measured value.

NOTE The -30 dB value is added because the formula used to calculate the value of the noise power in a 1 Hz BW when measured with a 1 kHz BW is:

Noise = 10 Log (BW 2/BW 1) where BW 2 is the 1 kHz BW we measure and BW 1 is 1 Hz BW we want to normalize to.

Therefore, 10 Log (1000) = 30 dB, so the noise floor will be 30 dB lower in a 1 Hz BW.

9. Enter the normalized value of the displayed average noise level in [Table 3-3](#).
10. The value of the normalized displayed average noise should be less than the specification value.
11. Change the analyzer center frequency to the next value listed in [Table 3-3](#)
12. Repeat steps 4 through 10 to fill in the remainder of [Table 3-3](#) for your analyzer frequency range.

Table 3-3 Displayed Average Noise Level (DANL) Results

Center Frequency	Measured Average Noise Level (dBm)	Normalized Average Noise Level/(1 Hz BW) (dBm)	Test Limits (dBm)
5 MHz			-140
2 GHz			-149
6 GHz			-147
13 GHz			-145
20 GHz			-142
26.5 GHz			-136
40 GHz			-124
50 GHz			-126

Frequency Readout Accuracy

Test Limits

Frequency Readout Accuracy is equivalent to the following equation:

$$\pm (0.25\% \times \text{span} + 5\% \times \text{RBW} + 2 \text{ Hz} + 0.5 \times \text{horizontal resolution})$$

NOTE See results table for actual values.

Test Description

The frequency readout accuracy is measured in several spans and center frequencies that allow both internal analyzer synthesizer modes and prefilter bandwidths to be tested. Frequency reference error is eliminated by using the same frequency standard for the analyzer and signal source.

Item	Critical Specification (for this test)	Recommended Agilent Model
Adapter	Type-N(m), to 3.5 mm(f)	1250-1744
Adapter	3.5 mm(f) to 3.5 mm(f)	5061-5311
Cable	APC 3.5 mm, 1 meter	8120-4921
Cable	BNC, 120 cm	10503A
Synthesized Sweeper	<i>Frequency</i> : Capable of 2 GHz (must have external reference input)	83630B

Figure 3-4. Frequency Readout Accuracy Test Setup

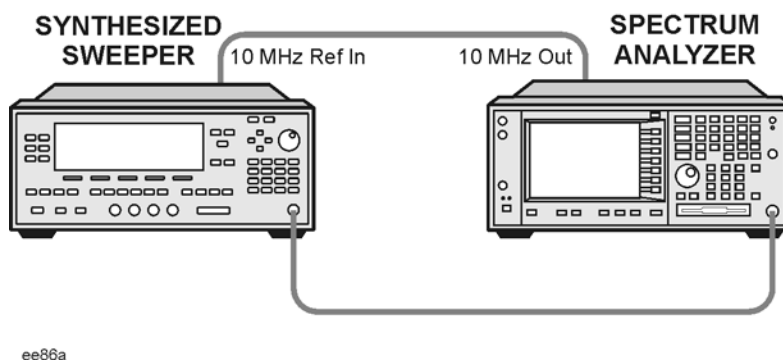

Procedure

1. Configure the equipment as shown in [Figure 3-4](#). Confirm the analyzer's built-in auto alignment has been performed within the past 24 hours.
2. Perform the following steps to set up the equipment:
 - a. On the synthesized sweeper, press **PRESET**, then set the controls as follows:
 - POWER LEVEL**, -10, dBm
 - CW**, 1505, MHz, RF (On)
 - b. On the spectrum analyzer, press **Preset**.
3. Set up the spectrum analyzer by pressing:
 - System, Reference**, 10, MHz, Ext (On)
 - Frequency**, 1505, MHz
 - Det/Demod, Detector**, Sample
 - Span**, 2990, MHz

NOTE Ensure Ref Level is set to 0 dBm. In addition, ensure Resolution BW and Video BW are both set to Auto.

4. Press **Peak Search** on the analyzer to measure the frequency readout accuracy. If the instrument is functioning correctly, the marker reading in the active function block will be between the values listed in [Table 3-4](#). Record the marker value in the Marker Frequency Readout column in [Table 3-4](#).
5. On the spectrum analyzer, change the span and center frequency as listed in [Table 3-4](#).
6. Change the synthesized sweeper frequency to match the center frequency of the analyzer.
7. Repeat steps 4 through 6 until the Marker Frequency Readout column of [Table 3-4](#) is complete.

Table 3-4 Frequency Readout Accuracy Results

Span (MHz)	Center Frequency (MHz)	Minimum	Marker Frequency Readout	Maximum
2990	1505	1.495 GHz		1.515 GHz
127.2	1505	1.5045 GHz		1.5055 GHz
54.1	1505	1.50480 GHz		1.50520 GHz
7.95	1505	1.504968 GHz		1.505032 GHz
0.106	1505	1.5049996 GHz		1.5050004 GHz
1.98	517.59	517.5829 MHz		517.5971 MHz
1.98	832.50	832.4928 MHz		832.5071 MHz

Frequency Response (Flatness)

Test Limits

Frequency Range	Limit Relative to 50 MHz
3 Hz to 3 GHz	±1.5 dB
> 3 GHz to 6.6 GHz	±2.5 dB
> 6.6 GHz to 22 GHz	±3.0 dB
> 22 GHz to 26.5 GHz	±3.5 dB
> 26.5 GHz	±3.5 dB

Test Description

The frequency response test measures the spectrum analyzer's amplitude error as a function of the tuned frequency. Measurements are made ranging from 50 MHz to the maximum frequency range of your analyzer. The signal source amplitude is measured with a power meter to eliminate error due to source flatness. The measured value is normalized to 50 MHz.

Item	Critical Specifications (for this test)	Recommended Agilent Model
Adapter	Type N(m) to 3.5 mm(m)	1250-1743
Adapter	Type N(m) to 3.5 mm(f)	1250-1744
Adapter ^a	2.4 mm(f) to 3.5 mm(m)	11901D
Adapter	3.5 mm(f) to 3.5 mm(f)	5061-5311
Cable	3.5 mm, 1 meter	8120-4921
Cables	BNC, 120 cm (48 in.)	10503A
Power Meter	Compatible with power sensor	E4418B
Power Sensor	<i>Frequency Range: 50 MHz to 26.5 GHz</i>	8485A
Power Sensor ^a	<i>Frequency Range: 50 MHz to 50 GHz</i>	8487D
Power Splitter	<i>Frequency Range: 50 MHz to 26.5 GHz</i> <i>Tracking between ports: < 0.25 dB</i>	11667B

PSA Functional Tests
 Frequency Response (Flatness)

Item	Critical Specifications (for this test)	Recommended Agilent Model
Power Splitter ^a	<i>Frequency Range: 50 MHz to 50 GHz Tracking between ports: < 0.25 dB</i>	11667C
Synthesized Sweeper	<i>Frequency Range: 50 MHz to 26 GHz</i>	83630B
Synthesized Sweeper ^a	<i>Frequency Range: 50 MHz to 50 GHz</i>	83650B

a. Only used for higher frequency PSA models (E4446A, E4448A), but can be used for testing all PSA models.

Figure 3-5. Frequency Response Test Setup

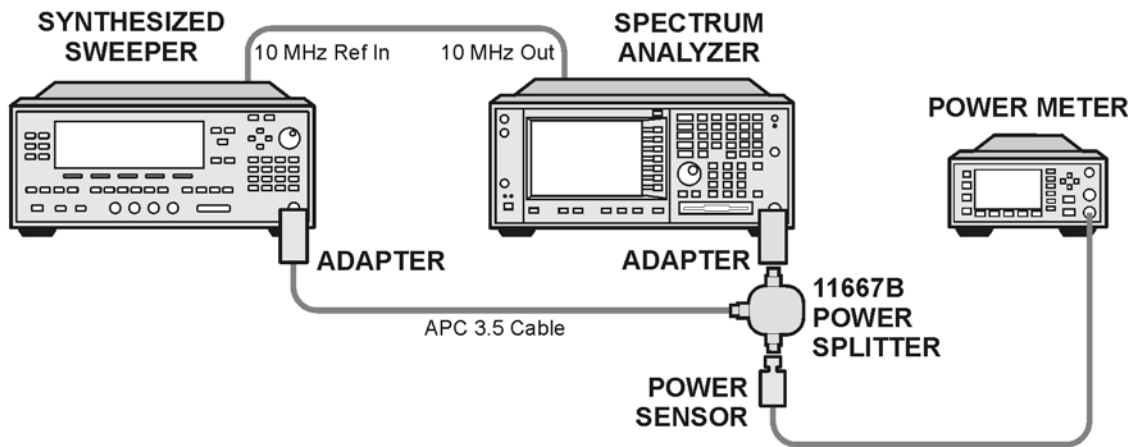

ee83a

Procedure

1. Zero and calibrate the power meter and power sensor as described in the power meter operation manual.
2. Configure the equipment as shown in [Figure 3-5](#).

NOTE Connect the power splitter to the spectrum analyzer input using the appropriate adapter. Do not use a cable.

3. Assure the spectrum analyzer's built-in auto alignment has been performed within the last 24 hours.
4. Preset (Factory Preset) both the spectrum analyzer and the synthesized sweeper.
5. Set up the synthesized sweeper by pressing:

CW, 50, MHz
Power level, -8, dBm

6. Set up the spectrum analyzer by pressing:
 - Frequency, 50, MHz**
 - Span, 50, kHz**
 - Amplitude (ref level), -10, dBm**
 - BW/Avg, Average (On), 10, Enter**
7. Adjust the synthesized sweeper output power for a power meter display of -14 dBm ±0.1 dB.

NOTE The power level of the synthesized sweeper remains unchanged for the duration of the test.

8. Press the **Peak Search** key on the signal analyzer to position the marker on the peak of the signal.
9. Refer to Table 3-5, “Frequency Response (Flatness) Results.” Enter the amplitude of the signal displayed on the spectrum analyzer into the Meas_{Amp} column of Table 3-5.
10. Enter the power meter reading into the Power_{Meter} column of Table 3-5.
11. Tune the synthesized sweeper and spectrum analyzer to the next frequency listed in Table 3-5.
12. Enter the power sensor calibration factor into the power meter.
13. For frequencies 3 GHz and above, press **Amplitude**, then **Presel Center** to center the preselector filter for an optimum amplitude measurement.
14. Repeat steps 8-13 and complete the remainder of Table 3-5 for the frequency range of your analyzer.
15. Compute the measurement error ($\text{Meas}_{\text{Error}} = \text{Meas}_{\text{Amp}} - \text{Power}_{\text{Meter}}$).
16. Compute the flatness error normalized to 50 MHz:
($\text{Meas}_{\text{Error}} - \text{Meas}_{\text{Error}} @ 50 \text{ MHz}$)
17. Enter the computed flatness error value into the Flat_{Norm} column of Table 3-5.
18. Compare the value of Flat_{Norm} to the test limit.

Table 3-5 Frequency Response (Flatness) Results

Center Frequency	Analyzer Amplitude Meas _{amp}	Power Meter Measurement Power _{meter}	Meas Error Meas _{error}	Flatness Normalized to 50 MHz Flat _{Norm}	Flatness Error Test Limits (dB)
50 MHz				0	Ref
1 GHz					±1.5
2 GHz					±1.5

Table 3-5 Frequency Response (Flatness) Results

Center Frequency	Analyzer Amplitude $Meas_{amp}$	Power Meter Measurement $Power_{meter}$	Meas Error $Meas_{error}$	Flatness Normalized to 50 MHz $Flat_{Norm}$	Flatness Error Test Limits (dB)
3 GHz					±1.5
3.5 GHz					±2.5
5 GHz					±2.5
6 GHz					±2.5
7 GHz					±3.0
10 GHz					±3.0
13 GHz					±3.0
14 GHz					±3.0
16 GHz					±3.0
22 GHz					±3.0
23 GHz					±3.5
25 GHz					±3.5
26.5 GHz					±3.5
28 GHz					±3.5
31.5 GHz					±3.5
42 GHz					±3.5
48 GHz					±3.5

Amplitude Linearity

Test Limits

The linearity error will be $\leq \pm 1.0$ dB with ≤ -10 dBm at the mixer.

Test Description

This test checks the amplitude linearity of the instrument by maintaining a constant reference level and measuring signals of different amplitudes over most of the display range. This test sets the input attenuator to 10 dB and the Reference Level to 0 dBm. The external attenuator is set to 0 dB, and the amplitude of the source is adjusted to set the displayed signal at the reference level.

The instrument's internal marker is used to measure the reference amplitude. The Marker Delta function is activated and the RF input is reduced using the external precision step attenuator. Signal input levels from 0 dBm to -50 dBm are measured.

Item	Critical Specifications (for this test)	Recommended Agilent Model
Adapter	Type-N(m), to BNC(f)	1250-1476
Adapter	3.5 mm(f) to 3.5mm(f)	5061-5311
Adapter	BNC(m) to SMA(f)	1250-1700
APC 3.5 mm (1 meter)	APC 3.5 mm, 1 meter	8120-4921
Attenuator, 10 dB Step	<i>Range: 0-50 dB</i> <i>Frequency: 50 MHz</i> <i>Accuracy: ± 0.25 dB</i>	355D
Cables (2 required)	BNC, 120 cm (48 in.)	10503A
Synthesized Sweeper	<i>Output Level Accuracy: 0 to -15 dBm: ± 1.0 dB</i>	83630B

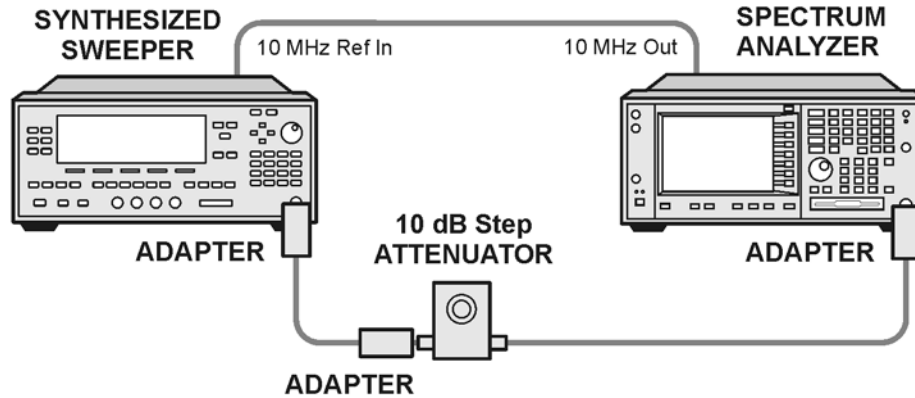
Figure 3-6. Amplitude Linearity Setup

ee84a

NOTE Averaging is used for all measurements to improve repeatability and reduce measurement uncertainty.

Procedure

1. Configure the equipment as shown in [Figure 3-6](#).
2. Set up the synthesized sweeper by pressing:

Frequency, 50, MHz
Amplitude, -2, dBm
RF On/Off, On

3. Set up the spectrum analyzer by pressing:

Preset (Factory Preset)
Frequency, 50, MHz
Span, Zero Span

NOTE On the analyzer, ensure the reference level is 0 dBm and the attenuator is set to 10 dB.

BW/AVG, 30, kHz
Average, 10, Enter
Marker (to turn on Marker function)

4. Set the external 10 dB step attenuator to 0 dB.
5. Adjust the amplitude on the signal source until the marker amplitude on the analyzer reads 0 dBm \pm 0.2 dB.
6. On the analyzer, press the Single key to trigger a 10 sweep average.
7. On the analyzer, activate the Marker Delta function by pressing **Marker, Delta**.

8. Perform the following steps for each attenuator setting listed in the table below:
 - a. Select the next External attenuator setting.
 - b. Press the **Single** key to trigger a 10 sweep average.
 - c. Enter the delta marker value into [Table 3-6](#).
 - d. Check delta marker reading against the test limits.

Table 3-6 Amplitude Linearity Results

External Attenuator Setting	Minimum (dB)	Marker Delta Value (dB)	Maximum (dB)
0	N/A	Reference	N/A
10	-11.0		-9.0
20	-21.0		-19.0
30	-31.0		-29.0
40	-41.0		-39.0
50	-51.0		-49.0

Second Harmonic Distortion (SHD)

Test Limits

Applied Frequency	Mixer Level	Distortion
40 MHz	-20 dBm	< -55 dBc

Test Description

This test checks the second harmonic distortion of the spectrum analyzer by tuning to twice the input frequency and examining the level of the distortion product. A low pass filter is inserted between the source and the spectrum analyzer to prevent the second harmonic from artificially raising the second harmonic product displayed on the analyzer.

The power level at the input mixer is 20 dB higher than specified to allow the distortion product to be seen. For example, the instrument specification may state that with a -40 dBm signal at the input mixer, the distortion product should be suppressed by > -75 dBc.

The equivalent Second Harmonic Intercept (SHI) is 35 dBm (-40 dBm + 75 dBc). This test is performed with -20 dBm at the mixer and verifies the distortion product is suppressed by -55 dBc. This ensures the SHI is also 35 dBm (-20 dBm + 55 dBc).

Item	Critical Specifications (for this test)	Recommended Agilent Model
Adapter	Type-N(m) to BNC(f)	1250-1476
Adapter	BNC(m) to SMA(f)	1250-1700
Cable	APC 3.5 mm, 1 meter	8120-4921
Cable	BNC, 120 cm	10503A
Filter, 50 MHz Low Pass	<i>Cutoff Frequency: 50 MHz</i> <i>Rejection at 65 MHz: > 40 dB</i> <i>Rejection at 75 MHz: > 60 dB</i>	0955-0306
Synthesized Sweeper	<i>Frequency: 50 MHz</i> <i>Spectral Purity: Better than -30 dBc</i>	83630B

Figure 3-7. Second Harmonic Distortion Test Setup

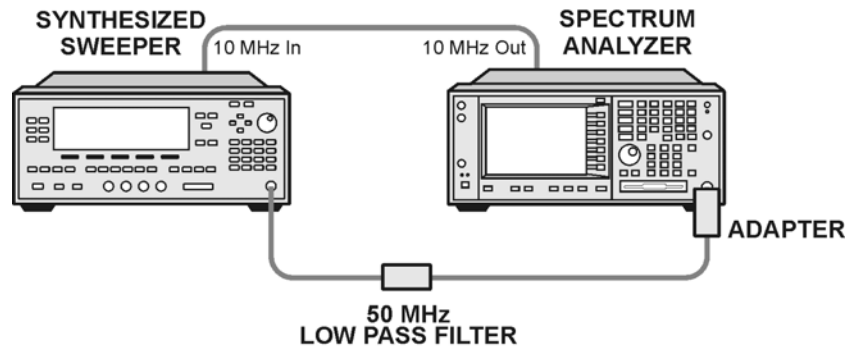

Procedure

1. Configure the equipment as shown in [Figure 3-7](#).
2. Press **Preset** (Factory Preset) on the spectrum analyzer and the synthesized sweeper.
3. Set up the spectrum analyzer by pressing:
 - Frequency, 40, MHz**
 - Amplitude, -10, dBm**
 - Span, 1 MHz**
4. Set up the synthesized sweeper by pressing:
 - CW Frequency, 40, MHz**
 - Level, -10, dBm**
 - RF (On)**
5. On the analyzer, press **Peak Search**.
6. Adjust the synthesized sweeper amplitude for a spectrum analyzer display of $-10 \text{ dBm} \pm 0.1 \text{ dBm}$.
7. On the analyzer, activate the marker delta function by pressing the **Marker** and **Delta** keys.
8. Set the analyzer Center Frequency to 80 MHz.
9. Press **BW/Avg, Average**, and enter the number 20, using the numeric keypad. Then, press **Enter** to begin the twenty sweep averaging routine and read the Marker Delta value. Enter the displayed value under the Measured Second Harmonic Distortion (dBc) heading in [Table 3-7](#).

PSA Functional Tests
Second Harmonic Distortion (SHD)

Table 3-7 Second Harmonic Distortion Results

Applied Frequency (MHz)	Measured Second Harmonic Distortion (dBc)	Specification (dBc)
40		<-55

4 ESA Functional Tests

Displayed Average Noise Level

Test Limits

Frequency Range	Model (50 Ω Input)	Maximum (50 Ω Input)	TR Entry
10 MHz to 500 MHz	E4401B, E4411B	- 119 dBm	1
501 MHz to 1.0 GHz	E4401B, E4411B	- 117 dBm	2
1.01 GHz to 1.5 GHz	E4401B	- 114 dBm	3
	E4411B	- 113 dBm	3
10 MHz to 1.0 GHz	E4402B, E4403B	- 117 dBm	4
	E4404B, E4405B, E4407B, E4408B	- 116 dBm	5
1.01 GHz to 2.0 GHz	E4402B, E4403B	- 116 dBm	6
	E4404B, E4405B, E4407B	- 116 dBm	7
	E4408B	- 115 dBm	8
2.01 GHz to 3.0 GHz	E4402B, E4403B	- 114 dBm	9
	E4404B, E4405B, E4407B, E4408B	- 112 dBm	10
3.01 GHz to 6.0 GHz	E4404B, E4405B, E4407B, E4408B	- 112 dBm	11
6.01 GHz to 6.7 GHz	E4404B	- 111 dBm	12
6.01 GHz to 12.0 GHz	E4405B, E4407B	- 111 dBm	13
	E4408B	- 110 dBm	14
12.01 GHz to 13.2 GHz	E4405B	- 107 dBm	15
12.01 GHz to 22 GHz	E4407B, E4408B	- 107 dBm	16
22.01 GHz to 26.5 GHz	E4407B	- 106 dBm	17
	E4408B	- 101 dBm	18

Frequency Range	Model (75 Ω Input)	Maximum (50 Ω Input)	TR Entry
10 MHz to 500 MHz	E4401B	- 66 dBmV	19
10 MHz to 500 MHz	E4411B	- 65 dBmV	20
501 MHz to 1.0 GHz	E4401B, E4411B	- 60 dBmV	21

Frequency Range	Model (75 Ω Input)	Maximum (50 Ω Input)	TR Entry
1.01 GHz to 1.5 GHz	E4401B	- 56 dBmV	22
1.01 GHz to 1.5 GHz	E4411B	- 53 dBmV	23

Test Description

The Displayed Average Noise Level is measured within the frequency range specified. The analyzer input is terminated in either 50 Ω or 75 Ω , depending on analyzer options.

The test tunes the analyzer frequency across the band, uses the marker to locate the frequency with the highest response, and then reads the average noise in zero span.

Item	Critical Specifications (for this test)	Recommended Agilent Model
Adapters		
Termination, 50 Ω Type-N (m)		908A
Additional Equipment for 75 Ω Input		
Termination, 75 Ω Type-N (m)		909E
Adapter, Type-N (f), to BNC (m), 75 Ω		1250-1534

Figure 4-1 Equipment Setup

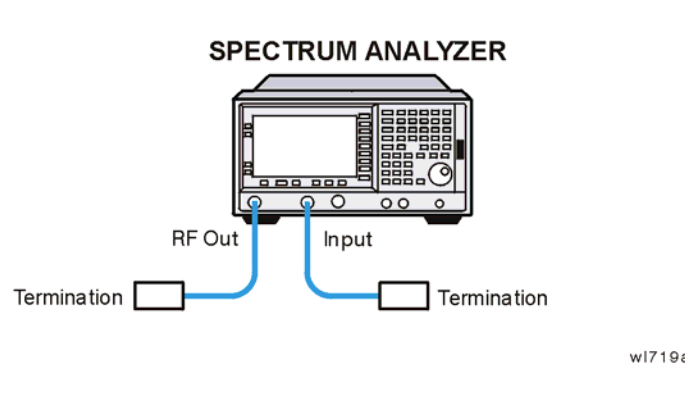

Procedure (10 MHz to 500 MHz) *E4401B and E4411B*

1. Connect the equipment as shown in [Figure 4-1](#).
2. Press **System, Power On/Preset, Preset Type (Factory), Preset** on the analyzer. Wait for the preset routine to finish. Set the analyzer by pressing the following keys:

FREQUENCY, Start Freq, 10, MHz
Stop Freq, 500, MHz

AMPLITUDE, -70, dBm (50 Ω Input only)
AMPLITUDE, More, Y Axis Units, dBmV (75 Ω Input only)
AMPLITUDE, Ref Level, -21.24, dBmV (75 Ω Input only)
BW/Avg, Res BW, 1, MHz
Video BW, 10, kHz

3. Press the following keys on the analyzer:

Single
BW/Avg, Average (On), 3, Enter
Single

Wait until **AVG 3** is displayed to the left of the graticule (the analyzer will take 3 sweeps, then stop).

4. Press **Peak Search**. Record the marker frequency next to your analyzer model in the Measured Frequency column as entry (a) or (b) in [Table 4-1 on page 141](#) for 10 MHz to 500 MHz.
5. Press the following keys on the analyzer:

Sweep, Sweep (Cont)
BW/Avg, Average (Off)
BW/Avg, Res BW (Auto)
Video BW (Auto)
SPAN, 50, kHz
FREQUENCY

6. Press **Center Freq**, and set the center frequency of the analyzer to the frequency recorded in the Measured Frequency column as entry (a) or (b) of [Table 4-1 on page 141](#) for 10 MHz to 500 MHz.
7. Press the following keys on the analyzer:

BW/Avg, Res BW, 1, kHz
Video BW, 30, Hz
Single

Wait for the sweep to finish.

8. Press the following keys on the analyzer:

Display, Display Line (On)

Adjust the display so that it is centered on the average trace noise, ignoring any residual responses.

9. Record the display line amplitude setting as TR Entry 1 (TR Entry 19 or 20 for a 75 Ω Input) in [Table 4-1 on page 141](#). The Average Noise Level should be less than the Maximum for the appropriate input impedance.

Procedure (501 MHz to 1.0 GHz) E4401B and E4411B

1. Press the following keys on the analyzer:

Sweep, Sweep (Cont)
FREQUENCY, Start Freq, 501, MHz
Stop Freq, 1.0, GHz
BW/Avg, Res BW, 1, MHz
Video BW, 10, kHz

2. Press the following keys on the analyzer:

Single
BW/Avg, Average (On), 3, **Enter**
Single

Wait until **AVG 3** is displayed to the left of the graticule (the analyzer will take 3 sweeps, then stop).

3. Press **Peak Search**, and record the marker frequency next to your analyzer model in the Measured Frequency column as entry (c) in [Table 4-1 on page 141](#) for 501 MHz to 1.0 GHz.
4. Press the following keys on the analyzer:

Sweep, Sweep (Cont)
BW/Avg, Average (Off)
BW/Avg, Res BW (Auto)
Video BW (Auto)
SPAN, 50, kHz
FREQUENCY

5. Press **Center Freq**. Set the center frequency of the analyzer to the frequency recorded in the Measured Frequency column as entry (c) in [Table 4-1 on page 141](#) for 501 MHz to 1.0 GHz.
6. Press the following keys on the analyzer:

BW/Avg, Res BW, 1, kHz
Video BW, 30, Hz
Single

Wait for the sweep to finish.

7. Press the following keys on the analyzer:

Display, Display Line (On)

Adjust the display line so that it is centered on the average trace noise, ignoring any residual responses.

8. Record the display line amplitude setting as TR Entry 2 (TR Entry 21 for a 75 Ω Input) in [Table 4-1 on page 141](#). The Average Noise Level should be less than the Maximum for the appropriate input impedance.

Procedure (1.01 GHz to 1.5 GHz) E4401B and E4411B

1. Press the following keys on the analyzer:

Sweep, Sweep (Cont)
FREQUENCY, Start Freq, 1.0 GHz
Stop Freq, 1.5 GHz
BW/Avg, Res BW, 1, MHz
Video BW, 10, kHz

2. Press the following keys on the analyzer:

Single
BW/Avg, Average (On), 3, **Enter**
Single

Wait until **AVG 3** is displayed to the left of the graticule (the analyzer will take 3 sweeps, then stop).

3. Press **Peak Search**, and record the marker frequency next to your analyzer model in the Measured Frequency column as entry (d) or (e) in [Table 4-1 on page 141](#) for 1.01 GHz to 1.5 GHz.

4. Press the following keys on the analyzer:

Sweep, Sweep (Cont)
BW/Avg, Average (Off)
BW/Avg, Res BW (Auto)
Video BW (Auto)
SPAN, 50, kHz
FREQUENCY

5. Press **Center Freq**. Set the center frequency of the analyzer to the frequency recorded in the Measured Frequency column as entry (d) or (e) in [Table 4-1 on page 141](#) for 1.01 GHz to 1.5 GHz.

6. Press the following keys on the analyzer:

BW/Avg, Res BW, 1, kHz
Video BW, 30, Hz
Single

Wait for the sweep to finish.

7. Press the following keys on the analyzer:

Display, Display Line (On)

Adjust the display line so that it is centered on the average trace noise, ignoring any residual responses.

8. Record the display line amplitude setting as TR Entry 3 (TR Entry 22 or 23 for a 75 Ω Input) in [Table 4-1 on page 141](#). The average noise level should be less than the Maximum for the appropriate input impedance.

Procedure (10 MHz to 1 GHz) *E4402B, E4403B, E4404B, E4405B, E4407B, E4408B*

1. Press **System, Power On/Presets, Preset Type (Factory), Preset** on the analyzer. Wait for the preset routine to finish. Set the analyzer by pressing the following keys:

FREQUENCY, Start Freq, 10, MHz
Stop Freq, 1.0, GHz

AMPLITUDE, -70, dBm
Attenuation (Man), 0, dB
BW/Avg, Res BW, 1, MHz
Video BW, 10, kHz

2. Press the following keys on the analyzer:

Single
BW/Avg, Average (On), 3, Enter
Single

Wait until **AVG 3** is displayed to the left of the graticule (the analyzer will take three sweeps, then stop).

3. Press **Peak Search**. Record the marker frequency next to your analyzer model in the Measured Frequency column as entry (f) or (g) in [Table 4-1 on page 141](#) for 10 MHz to 1.0 GHz.
4. Press the following keys on the analyzer:

Sweep, Sweep (Cont)
BW/Avg, Average (Off)
BW/Avg, Res BW (Auto)
Video BW (Auto)
SPAN, 50, kHz
FREQUENCY

5. Press **Center Freq**. Set the center frequency of the analyzer to the frequency recorded in the Measured Frequency column as entry (f) or (g) in [Table 4-1 on page 141](#) for 10 MHz to 1.0 GHz.
6. Press the following keys on the analyzer:

BW/Avg, Res BW, 1, kHz
Video BW, 30, Hz
Single

Wait for the sweep to finish.

7. Press the following keys on the analyzer:

Display, Display Line (On)

Adjust the display line so that it is centered on the average trace noise, ignoring any residual responses.

8. If the analyzer is an E4402B or E4403B, record the display line amplitude setting as TR Entry 4 in [Table 4-1 on page 141](#). Otherwise, record the display line amplitude setting as TR Entry 5 in [Table 4-1 on page 141](#). The average noise level should be less than the Maximum.

Procedure (1.01 GHz to 2 GHz) *E4402B, E4403B, E4404B, E4405B, E4407B, E4408B*

1. Press **System, Power On/Presets, Preset Type (Factory), Preset** on the analyzer. Wait for the preset routine to finish. Set the analyzer by pressing the following keys:

**FREQUENCY, Start Freq, 1.01, GHz
Stop Freq, 2, GHz**

**AMPLITUDE, -70, dBm
Attenuation (Man), 0, dB
BW/Avg, Res BW, 1, MHz
Video BW, 10, kHz**

2. Press the following keys on the analyzer:

**Single
BW/Avg, Average (On), 3, Enter
Single**

Wait until **AVG 3** is displayed to the left of the graticule (the analyzer will take 3 sweeps and then stop).

3. Press **Peak Search**. Record the marker frequency next to your analyzer model in the Measured Frequency column as entry (h), (i) or (j) in [Table 4-1 on page 141](#) for 1.01 GHz to 2 GHz.

4. Press the following keys on the analyzer:

**Sweep, Sweep (Cont)
BW/Avg, Average (Off)
BW/Avg, Res BW (Auto)
Video BW (Auto)
SPAN, 50, kHz
FREQUENCY**

5. Press **Center Freq**. Set the center frequency of the analyzer to the frequency recorded in the Measured Frequency column as entry (h), (i) or (j) in [Table 4-1 on page 141](#) for 1.01 GHz to 2 GHz.

6. Press the following keys on the analyzer:

**BW/Avg, Res BW, 1, kHz
Video BW, 30, Hz
Single**

Wait for the sweep to finish.

7. Press the following keys on the analyzer:

Display, Display Line (On)

Adjust the display line so that it is centered on the average trace noise, ignoring any residual responses.

8. If the analyzer is an E4402B or E4403B, record the display line amplitude setting as TR Entry 6 in [Table 4-1 on page 141](#). Otherwise, record the display line amplitude setting as TR Entry 7 or 8 in [Table 4-1 on page 141](#). The average noise level should be less than the Maximum.

Procedure (2.01 GHz to 3.0 GHz) E4402B, E4403B, E4404B, E4405B, E4407B, E4408B

1. Press **System, Power On/Preset, Preset Type (Factory), Preset** on the analyzer. Wait for the preset routine to finish. Set the analyzer by pressing the following keys:

**FREQUENCY, Start Freq, 2.01, GHz
 Stop Freq, 3.0, GHz**

**AMPLITUDE, -70, dBm
 Attenuation (Man), 0, dB
 BW/Avg, Res BW, 1, MHz
 Video BW, 10, kHz**

2. Press the following keys on the analyzer:

**Single
 BW/Avg, Average (On), 3, Enter
 Single**

Wait until **AVG 3** is displayed to the left of the graticule (the analyzer will take 3 sweeps and then stop).

3. Press **Peak Search**. Record the marker frequency next to your analyzer model in the Measured Frequency column as entry (k) or (l) in [Table 4-1 on page 141](#) for 2.01 GHz to 3.0 GHz.
4. Press the following keys on the analyzer:

**Sweep, Sweep (Cont)
 BW/Avg, Average (Off)
 BW/Avg, Res BW (Auto)
 Video BW (Auto)
 SPAN, 50, kHz
 FREQUENCY**

5. Press **Center Freq**. Set the center frequency of the analyzer to the frequency recorded in the Measured Frequency column as entry (k) or (l) in [Table 4-1 on page 141](#) for 2.01 GHz to 3.0 GHz.

6. Press the following keys on the analyzer:

**BW/Avg, Res BW, 1, kHz
 Video BW, 30, Hz**

Single

Wait for the sweep to finish.

7. Press the following keys on the analyzer:

Display, Display Line (On)

Adjust the display line so that it is centered on the average trace noise, ignoring any residual responses.

8. If the analyzer is an E4402B or E4403B, record the display line amplitude setting as TR Entry 9 in [Table 4-1 on page 141](#) Otherwise, record the display line amplitude setting as TR Entry 10 in [Table 4-1 on page 141](#) The Average Noise Level should be less than the maximum.

Procedure (3.01 GHz to 6.0 GHz) *E4404B, E4405B, E4407B, and E4408B*

1. Press **System, Power On/Preset, Preset Type (Factory), Preset** on the analyzer. Wait for the preset routine to finish. Set the analyzer by pressing the following keys:

**FREQUENCY, Start Freq, 3.01, GHz
Stop Freq, 6.0. GHz**

**AMPLITUDE, -70, dBm
Attenuation (Man), 0, dB
BW/Avg, Res BW, 1, MHz
Video BW, 10, kHz**

2. Press the following keys on the analyzer:

**Single
BW/Avg, Average (On), 3, Enter
Single**

Wait until **AVG 3** is displayed to the left of the graticule (the analyzer will take 3 sweeps and then stop).

3. Press **Peak Search**. Record the marker frequency next to your analyzer model in the Measured Frequency column as entry (m) in [Table 4-1 on page 141](#) for 3.01 GHz to 6.0 GHz.

4. Press the following keys on the analyzer:

**Sweep, Sweep (Cont)
BW/Avg, Average (Off)
BW/Avg, Res BW (Auto)
Video BW (Auto)
SPAN, 50, kHz
FREQUENCY**

5. Press **Center Freq**. Set the center frequency of the analyzer to the frequency recorded in the Measured Frequency column as entry (m) in [Table 4-1 on page 141](#) for 3.01 GHz to

6.0 GHz.

6. Press the following keys on the analyzer:

BW/Avg, Res BW, 1, kHz
Video BW, 30, Hz
Single

Wait for the sweep to finish.

7. Press the following keys on the analyzer:

Display, Display Line (On)

Adjust the display line so that it is centered on the average trace noise, ignoring any residual responses.

8. Record the display line amplitude setting as TR Entry 11 in [Table 4-1 on page 141](#). The Average Noise Level should be less than the Maximum.

Procedure (6.01 GHz to 6.7 GHz) E4404B

1. Press **System, Power On/Presets, Preset Type (Factory), Preset** on the analyzer. Wait for the preset routine to finish. Set the analyzer by pressing the following keys:

FREQUENCY, Start Freq, 6.01, GHz
Stop Freq, 6.7, GHz

AMPLITUDE, -70, dBm
Attenuation (Man), 0, dB
BW/Avg, Res BW, 1, MHz
Video BW, 10, kHz

2. Press the following keys on the analyzer:

Single
BW/Avg, Average (On), 3, Enter
Single

Wait until **AVG 3** is displayed to the left of the graticule (the analyzer will take 3 sweeps and then stop).

3. Press **Peak Search**. Record the marker frequency next to your analyzer model in the Measured Frequency column as entry (n) in [Table 4-1 on page 141](#) for 6.01 GHz to 6.7 GHz.

4. Press the following keys on the analyzer:

Sweep, Sweep (Cont)
BW/Avg, Average (Off)
BW/Avg, Res BW (Auto)
Video BW (Auto)
SPAN, 50, kHz
FREQUENCY

5. Press **Center Freq**. Set the center frequency of the analyzer to the frequency recorded in the Measured Frequency column as entry (n) in [Table 4-1 on page 141](#) for 6.01 GHz to 6.7 GHz.

6. Press the following keys on the analyzer:

BW/Avg, Res BW, 1, kHz
Video BW, 30, Hz
Single

Wait for the sweep to finish.

7. Press the following keys on the analyzer:

Display, Display Line (On)

Adjust the display line so that it is centered on the average trace noise, ignoring any residual responses.

8. Record the display line amplitude setting as TR Entry 12 in [Table 4-1 on page 141](#). The Average Noise Level should be less than the Maximum.

Procedure (6.01 GHz to 12.0 GHz) *E4405B, E4407B, and E4408B*

1. Press **System, Power On/Preset, Preset Type (Factory), Preset** on the analyzer. Wait for the preset routine to finish. Set the analyzer by pressing the following keys:

FREQUENCY, Start Freq, 6.01, GHz
Stop Freq, 12.0, GHz

AMPLITUDE, -70, dBm
Attenuation (Man), 0, dB
BW/Avg, Res BW, 1, MHz
Video BW, 10, kHz

2. Press the following keys on the analyzer:

Single
BW/Avg, Average (On), 3, Enter
Single

Wait until **AVG 3** is displayed to the left of the graticule (the analyzer will take 3 sweeps and then stop).

3. Press **Peak Search**. Record the marker frequency next to your analyzer model in the Measured Frequency column as entry (o) or (p) in [Table 4-1 on page 141](#) for 6.01 GHz to 12.0 GHz.

4. Press the following keys on the analyzer:

Sweep, Sweep (Cont)
BW/Avg, Average (Off)
BW/Avg, Res BW (Auto)
Video BW (Auto)
SPAN, 50, kHz

FREQUENCY

5. Press **Center Freq**. Set the center frequency of the analyzer to the frequency recorded in the Measured Frequency column as entry (o) or (p) in [Table 4-1 on page 141](#) for 6.01 GHz to 12.0 GHz.
6. Press the following keys on the analyzer:

BW/Avg, Res BW, 1, kHz
Video BW, 30, Hz
Single

Wait for the sweep to finish.

7. Press the following keys on the analyzer:

Display, Display Line (On)

Adjust the display line so that it is centered on the average trace noise, ignoring any residual responses.

8. Record the display line amplitude setting as TR Entry 13 or 14 in [Table 4-1 on page 141](#). The average noise level should be less than the Maximum.

Procedure (12.01 GHz to 13.2 GHz) *E4405B*

1. Press **Preset System, Power On/Presets, Preset Type (Factory), Preset**, on the analyzer. Wait for the preset routine to finish. Set the analyzer by pressing the following keys:

FREQUENCY, Start Freq, 12.01, GHz
Stop Freq, 13.2, GHz

AMPLITUDE, -70, dBm
Attenuation (Man), 0, dB
BW/Avg, Res BW, 1, MHz
Video BW, 10, kHz

2. Press the following keys on the analyzer:

Single
BW/Avg, Average (On), 3, Enter
Single

Wait until **AVG 3** is displayed to the left of the graticule (the analyzer will take 3 sweeps and then stop).

3. Press **Peak Search**. Record the marker frequency next to your analyzer model in the Measured Frequency column as entry (q) in [Table 4-1 on page 141](#) for 12.01 GHz to 13.2 GHz.
4. Press the following keys on the analyzer:

Sweep, Sweep (Cont)
BW/Avg, Average (Off)
BW/Avg, Res BW (Auto)

Video BW (Auto)
SPAN, 50, kHz
FREQUENCY

5. Press **Center Freq**. Set the center frequency of the analyzer to the frequency recorded in the Measured Frequency column as entry (q) in [Table 4-1 on page 141](#) for 12.01 GHz to 13.2 GHz.
6. Press the following keys on the analyzer:

BW/Avg, Res BW, 1, kHz
Video BW, 30, Hz
Single

Wait for the sweep to finish.

7. Press the following keys on the analyzer:

Display, Display Line (On)

Adjust the display line so that it is centered on the average trace noise, ignoring any residual responses.

8. Record the display line amplitude setting as TR Entry 15 in [Table 4-1 on page 141](#). The Average Noise Level should be less than the Maximum.

Procedure (12.01 GHz to 22 GHz) E4407B and E4408B

1. Press **System, Power On/Preset, Preset Type** (Factory), **Preset** on the analyzer. Wait for the preset routine to finish. Set the analyzer by pressing the following keys:

FREQUENCY, Start Freq, 12.01, GHz
Stop Freq, 22, GHz

AMPLITUDE, -70, dBm
Attenuation (Man), 0, dB
BW/Avg, Res BW, 1, MHz
Video BW, 10, kHz

2. Press the following keys on the analyzer:

Single
BW/Avg, Average (On), 3, **Enter**
Single

Wait until **AVG 3** is displayed to the left of the graticule (the analyzer will take 3 sweeps and then stop).

3. Press **Peak Search**. Record the marker frequency next to your analyzer model in the Measured Frequency column as entry (r) in [Table 4-1 on page 141](#) for 12.01 GHz to 22 GHz.
4. Press the following keys on the analyzer:

Sweep, Sweep (Cont)
BW/Avg, Average (Off)
BW/Avg, Res BW (Auto)

Video BW (Auto)
SPAN, 50, kHz
FREQUENCY

5. Press **Center Freq.** Set the center frequency of the analyzer to the frequency recorded in the Measured Frequency column as entry (r) in [Table 4-1 on page 141](#) for 12.01 GHz to 22 GHz.
6. Press the following keys on the analyzer:

BW/Avg, Res BW, 1, kHz
Video BW, 30, Hz
Single

Wait for the sweep to finish.

7. Press the following keys on the analyzer:

Display, Display Line (On)

Adjust the display line so that it is centered on the average trace noise, ignoring any residual responses.

8. Record the display line amplitude setting as TR Entry 16 in [Table 4-1 on page 141](#). The Average Noise Level should be less than the Maximum.

Procedure (22.01 GHz to 26.5 GHz) E4407B and E4408B

1. Press **System, Power On/Preset, Preset Type (Factory), Preset** on the analyzer. Wait for the preset routine to finish. Set the analyzer by pressing the following keys:

FREQUENCY, Start Freq, 22.01, GHz
Stop Freq, 26.5, GHz

AMPLITUDE, -70, dBm
Attenuation (Man), 0, dB
BW/Avg, Res BW, 1, MHz
Video BW, 10, kHz

2. Press the following keys on the analyzer:

Single
BW/Avg, Average (On), 3, Enter
Single

Wait until AVG 3 is displayed to the left of the graticule (the analyzer will take 3 sweeps and then stop).

3. Press **Peak Search**. Record the marker frequency next to your analyzer model in the Measured Frequency column as entry (s) or (t) in [Table 4-1 on page 141](#) for 22.01 GHz to 26.5 GHz.
4. Press the following keys on the analyzer:

Sweep, Sweep (Cont)
BW/Avg, Average (Off)
BW/Avg, Res BW (Auto)

Video BW (Auto)
SPAN, 50, kHz
FREQUENCY

5. Press **Center Freq**. Set the center frequency of the analyzer to the frequency recorded in the Measured Frequency column as entry (s) or (t) in [Table 4-1 on page 141](#) for 22.01 GHz to 26.5 GHz.

6. Press the following keys on the analyzer:

BW/Avg, Res BW, 1, kHz
Video BW, 30, Hz
Single

Wait for the sweep to finish.

7. Press the following keys on the analyzer:

Display, Display Line (On)

Adjust the display line so that it is centered on the average trace noise, ignoring any residual responses.

8. Record the display line amplitude setting as TR Entry 17 or 18 in [Table 4-1 on page 141](#). The Average Noise Level should be less than the Maximum.

Table 4-1 Display Average Noise Level Worksheet

Model Number	Frequency Range	Measured Frequency	Average Noise Level (TR Entry)	Maximum	
				50 Ω Input	75 Ω Input
E4401B	10 MHz to 500 MHz	(a) _____	(1) or (19) _____	- 119 dBm	- 66 dBmV
E4411B	10 MHz to 500 MHz	(b) _____	(1) or (20) _____	- 119 dBm	- 65 dBmV
E4401B, E4411B	501 MHz to 1.0 GHz	(c) _____	(2) or (21) _____	- 117 dBm	- 60 dBmV
E4401B	1.01 GHz to 1.5 GHz	(d) _____	(3) or (22) _____	- 114 dBm	- 56 dBmV
E4411B	1.01 GHz to 1.5 GHz	(e) _____	(3) or (23) _____	- 113 dBm	- 53 dBmV
E4402B, E4403B	10 MHz to 1.0 GHz	(f) _____	(4) _____	- 117 dBm	N/A
E4404B, E4405B, E4407B, E4408B	10 MHz to 1.0 GHz	(g) _____	(5) _____	- 116 dBm	N/A
E4402B, E4403B	1.01 GHz to 2.0 GHz	(h) _____	(6) _____	- 116 dBm	N/A
E4404B, E4405B, E4407B	1.01 GHz to 2.0 GHz	(i) _____	(7) _____	- 116 dBm	N/A
E4408B	1.01 GHz to 2.0 GHz	(j) _____	(8) _____	- 115 dBm	N/A
E4402B, E4403B	2.01 GHz to 3.0 GHz	(k) _____	(9) _____	- 114 dBm	N/A
E4404B, E4405B, E4407B, E4408B	2.01 GHz to 3.0 GHz	(l) _____	(10) _____	- 112 dBm	N/A
E4404B, E4405B, E4407B, E4408B	3.01 GHz to 6.0 GHz	(m) _____	(11) _____	- 112 dBm	N/A
E4404B	6.01 GHz to 6.7 GHz	(n) _____	(12) _____	- 111 dBm	N/A
E4405B, E4407B	6.01 GHz to 12.0 GHz	(o) _____	(13) _____	- 111 dBm	N/A
E4408B	6.01 GHz to 12.0 GHz	(p) _____	(14) _____	- 110 dBm	N/A
E4405B	12.01 GHz to 13.2 GHz	(q) _____	(15) _____	- 107 dBm	N/A
E4407B, E4408B	12.01 GHz to 22 GHz	(r) _____	(16) _____	- 107 dBm	N/A
E4407B	22.01 GHz to 26.5 GHz	(s) _____	(17) _____	- 106 dBm	N/A
E4408B	22.01 GHz to 26.5 GHz	(t) _____	(18) _____	- 101 dBm	N/A

Frequency Readout Accuracy

Test Limits

Span	Minimum)	Maximum
10 MHz	1.48988 GHz	1.49012 GHz
100 kHz	1.4899988 GHz	1.4900012 GHz
Marker Count Accuracy with Counter Resolution at 1 Hz	1.489999999 GHz	1.490000001 GHz

Test Description

The frequency readout accuracy of the analyzer is tested with an input signal of known frequency. Frequency reference error is eliminated by using the same frequency standard for the analyzer and the synthesized sweeper.

Item	Critical Specifications (for this test)	Recommended Agilent Model
Signal Sources		
Synthesized Sweeper	10 MHz to 1.5 GHz External Reference Input	8340A/B or 836XX Series
Adapters		
Type-N (f), to APC 3.5(f)		1250-1745
Cables		
Type-N, 152-cm (60-in)		11500D
BNC, 122-cm (48-in)		10503A
Additional Equipment for 75-Ohm Input		
Pad, minimum loss		11852B
Type-N (f), to BNC (m), 75 Ω		1250-1534

Figure 4-2 Equipment Setup

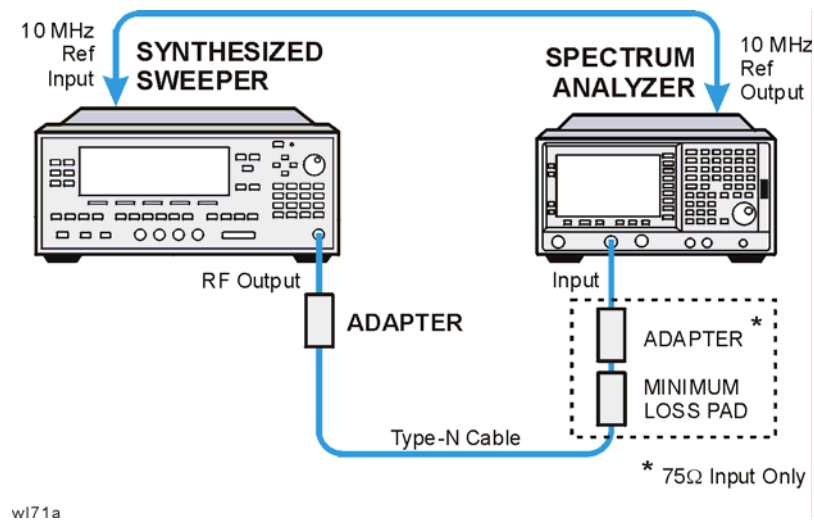

Procedure

1. Connect the equipment as shown in [Figure 4-2](#). Remember to connect the 10 MHz REF OUT of the analyzer to the 10 MHz REF IN of the synthesized sweeper.
2. Perform the following steps to set up the equipment:
 - a. Press **INSTRUMENT PRESET** on the synthesized sweeper, then set the controls as follows:
 - CW, 1.490, GHz**
 - POWER LEVEL, 10, – dBm**
 - b. Press **System, Power On/Preset, Preset Type** (Factory), **Preset** on the analyzer, then wait for the preset routine to finish. Set the analyzer by pressing the following keys:
 - Frequency, 1.490, GHz**
 - SPAN, 10, MHz**
 - BW/Avg, Res BW, 100, kHz**
 - Video BW, 30, kHz**

CAUTION Use only 75 Ω cables, connectors, or adapters on analyzers with 75 Ω inputs, or damage to connectors will occur.

3. Press **Peak Search** on the analyzer to measure the frequency readout accuracy. Record this in the Marker Frequency Readout column in [Table 4-2 on page 145](#).
4. Press **Span, 100, kHz, BW/Avg, Res BW, 1, kHz, Video BW, 1, kHz**.
5. Press **Peak Search** on the analyzer to measure the frequency readout accuracy. Record this in the Marker Frequency Readout column in [Table 4-2 on page 145](#).

NOTE The Frequency Readout Accuracy is now complete. Continue with the Marker Count Accuracy functional check.

Marker Count Accuracy

Procedure

1. Press **System, Power On/Preset, Preset Type (Factory), Preset** on the analyzer, then wait for the preset routine to finish. Set the analyzer to measure the marker count accuracy by pressing the following keys:

Frequency, 1.490, GHz
SPAN, 10, MHz
BW/Avg, Res BW, 100, kHz
Freq Count, Resolution, 1, Hz

2. Press **Peak Search**, then wait for a count to be taken (it may take several seconds).
3. Record the **cnt:r1** frequency as the Marker Frequency Readout in [Table 4-2](#).

Table 4-2 Frequency Readout and Marker Count Accuracy Worksheet

Span	Minimum	Marker Frequency Readout	Maximum
10 MHz	1.48988 GHz		1.49012 GHz
100 kHz	1.4899988 GHz		1.4900012 GHz
Marker Count Accuracy w/Counter Resolution at 1 Hz	1.489999999 GHz		1.490000001 GHz

Frequency Response (Flatness)

Test Limits

ESA Model	Frequency	Minimum (dB)	Maximum (dB)
E4411B & E4401B	9 kHz to 1.5 GHz	-1.5	1.5
E4402B & E4403B	9 kHz to 3 GHz	-1.5	1.5
E4404B	9 kHz to 3 GHz	-1.5	1.5
	3.01 GHz to 6.7 GHz	-3.0	3.0
E4405B	9 kHz to 3 GHz	-1.5	1.5
	3.01 GHz to 6.7 GHz	-3.0	3.0
	6.71 GHz to 13.2 GHz	-3.5	3.5
E4407B & E4408B	9 kHz to 3 GHz	-1.5	1.5
	3.01 GHz to 6.7 GHz	-3.0	3.0
	6.71 GHz to 13.2 GHz	-3.5	3.5
	13.21 GHz to 25 GHz	-4.0	4.0
	25 GHz to 26.5 GHz	-4.5	4.5

Test Description

The output of the synthesized sweeper is fed through a power splitter to a power sensor and the analyzer. The synthesized sweeper's power level is adjusted at 50 MHz to place the displayed signal at the analyzer center horizontal graticule line. Measurements are made at various points depending on the model being tested. The signal source amplitude is measured with a power meter to eliminate errors due to source flatness. The power meter is zeroed and calibrated before starting the measurement.

Item	Critical Specifications (for this test)	Recommended Agilent Model
Signal Sources		
Synthesized Sweeper		8340A/B or 836xx Series
Adapters		
Type-N (f) to BNC (f)		1250-1474
APC 3.5 (f) to APC 3.5 (f)		5061-5311
BNC (f) to SMA (m)		1250-1237

Item	Critical Specifications (for this test)	Recommended Agilent Model
Type-N (m), to APC 3.5(m)		1250-1743
Cables		
(2) APC 3.5mm (36 in)	E4407B and E4408B only	8120-4921 or 11500E
BNC (m) both ends, (48 in)		10503A
Additional Equipment for 75-Ohm Input		
Pad, minimum loss		11852B
Type-N (f), to BNC (m)		1250-1534
Miscellaneous		
Power Meter		EPM-441A (E4418A)
Power Sensor, 75 Ω		8483A
Power Sensor, 50 Ω		8485A
Power Splitter		11667B

Figure 4-3 Equipment Setup

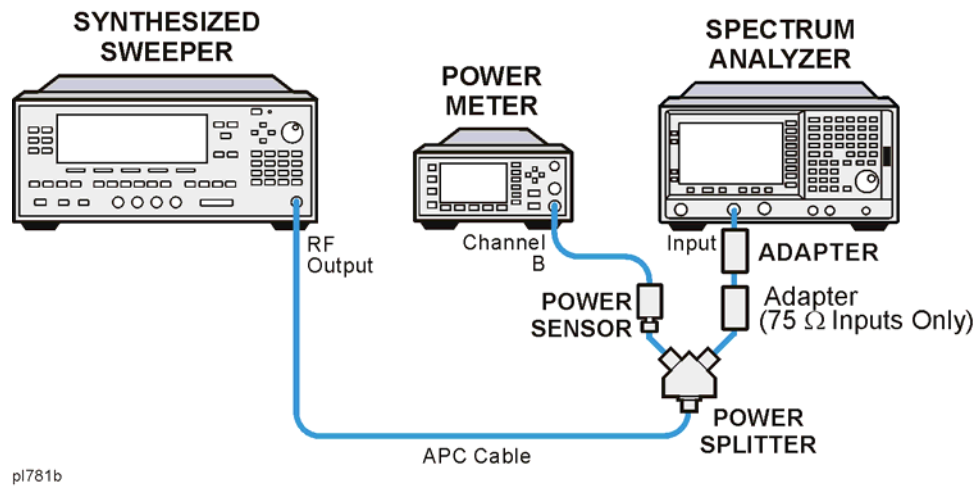

Procedure

1. Zero and calibrate the power meter and power sensor as described in the power meter operation manual.
2. Connect the equipment as shown in [Figure 4-3](#).

CAUTION Use only 75 Ω cables, connectors, or adapters on analyzers with 75 Ω connectors, or damage to the connectors will occur.

3. Set the synthesized sweeper controls as follows:

FREQUENCY, Center Freq, 50, MHz

POWER LEVEL, -8, dBm

4. Press **System, Power On/Preset, Preset Type (Factory), Preset** on the analyzer and wait for the preset routine to finish. Set the analyzer by pressing the following keys.

FREQUENCY, 50, MHz

CF Step, 50, MHz

SPAN, 20, kHz

AMPLITUDE, More, Y Axis Units, dBm

AMPLITUDE, -10, dBm

AMPLITUDE, Attenuation, 10, dB

Scale/Div, 2, dB

BW/Avg, Res BW, 10, kHz

Video BW, 3, kHz

Peak Search

FREQUENCY, Signal Track (On)

5. Adjust the synthesized sweeper power level for a marker amplitude reading of -14 dBm +/- 0.10 dB.

NOTE The power level of the synthesized sweeper remains unchanged for the duration of the test. For each new test frequency, the power sensor cal factor should be entered to minimize measurement errors.

6. Refer to [Table 4-3 on page 150](#) Enter the marker readout amplitude for 50 MHz as displayed on the analyzer in the Analyzer Amplitude column.

7. Enter the power meter reading in the Power Meter Amplitude column.

8. Compute the flatness error at 50 MHz using the following equation and record the results in the Flatness Error column:

Flatness Error = Analyzer Amplitude - Power Meter Amplitude

9. Perform the following steps for each center frequency setting listed in [Table 4-3 on page 150](#).

- Tune the source to the next frequency listed in the Center Frequency column.
- Enter the power sensor cal factor for the new test frequency.
- Tune the analyzer center frequency by pressing the \uparrow key or press **FREQUENCY, Center Freq, "n", and MHz** (where "n" is the next test frequency in [Table 4-3 on page 150](#)).
- Press **Peak Search**.

- e. Enter the power meter reading in the Power Meter Amplitude column.
- f. Enter the analyzer reading in the Analyzer Amplitude column.
- g. Compute the flatness error using the following equation and record the results in the Flatness Error column:

$$\text{Flatness Error} = \text{Analyzer Amplitude} - \text{Power Meter Amplitude}$$

The flatness error should be less than the specified amount.

Table 4-3 Frequency Response Worksheet

Model	Center Freq	Analyzer Amplitude	Power Meter Amplitude	Flatness Error	Flatness Error Test Limits (dB)
All Models	50 MHz				± 1.5
	100 MHz				± 1.5
	750 MHz				± 1.5
	1250 MHz				± 1.5
	1500 MHz				± 1.5
E4402B – E4408B	2000 MHz				± 1.5
	2500 MHz				± 1.5
	2999 MHz				± 1.5
E4402B – E4408B	4250 MHz				± 3.0
	5750 MHz				± 3.0
	6699 MHz				± 3.0
E4402B – E4408B	8000 MHz				± 3.5
	9000 MHz				± 3.5
	10000 MHz				± 3.5
	11000 MHz				± 3.5
	13199 MHz				± 3.5
E4407B & E4408B	14000 MHz				± 4.0
	19000 MHz				± 4.0
	24000 MHz				± 4.0
	26500 MHz				± 4.5

Reference Level Accuracy

Test Limits

Reference Level		Minimum (dB)	Maximum (dB)
dBm	dBmV		
-30	21.76	Reference	Reference
-20	31.76	-1.40	1.40
-10	41.76	-1.40	1.40
-40	11.76	-1.40	1.40
-50	1.76	-1.40	1.40
-60	-8.24	-1.40	1.40
-70	-18.24	-2.0	2.0

Test Description

A 50 MHz CW signal is applied to the Input of the analyzer. The amplitude of the source and the analyzer's reference level are decreased in 10 dB steps. The analyzer marker functions are used to measure the amplitude difference between steps. Reference Level Accuracy is tested in both Log and Linear Scale Modes. Most of the error is contributed from the output attenuator inaccuracy in the synthesized sweeper and not the analyzer.

Item	Critical Specifications (for this test)	Recommended Agilent Model
Signal Sources		
Synthesized Sweeper	Output Level Accuracy 0 to -15 dBm: ± 1.0 dB -16 dBm to -63 dBm: ± 1.4 dB ≤ -64 dBm: ≥ 2.0 dB	8340A/B or 836XX Series
Adapters		
Type-N (m), to BNC f)		1250-1476
Cables		
Type-N, 152-cm (60-in)		11500D
BNC, 122-cm (48-in)		10503A
Additional Equipment for 75-Ohm Input		
Pad, minimum loss		11852B

Item	Critical Specifications (for this test)	Recommended Agilent Model
Type-N (f), to BNC (m)		1250-1534

Figure 4-4 Equipment Setup

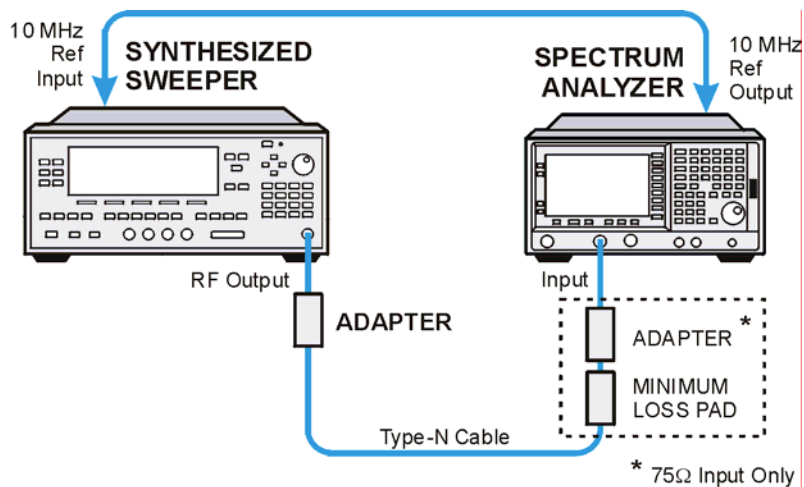

w171a

Log Mode Procedure

1. Connect the equipment as shown in [Figure 4-4](#).
2. Press **PRESET** on the synthesized sweeper. Set the synthesized sweeper controls as follows:
 - CW, 50, MHz**
 - Power Level, -30, dBm**
3. Press **System, Power On/Preset, Preset Type (Factory), Preset** on the analyzer, then wait for the preset routine to finish. Press **System, Alignments, Auto Align, Off**. Set the analyzer by pressing the following keys:
 - FREQUENCY, Center Freq, 50, MHz**
 - SPAN, 50, kHz**
 - AMPLITUDE, -30, dBm (50 Ω Input only)**
 - AMPLITUDE, More, Y Axis Units, dBmV (75 Ω Input only)**
 - AMPLITUDE, 21.76, dBmV (75 Ω Input only)**
 - Attenuation (Man), 5, dB**
 - BW/Avg, Res BW, 3, kHz**
 - Video BW, 30, Hz**
4. Press **Peak Search** on the analyzer. Adjust the amplitude on the synthesized sweeper until the marker amplitude on the analyzer reads $-30 \text{ dBm} \pm 0.10 \text{ dB}$. Enter the synthesized sweeper power level as the Synthesized Sweeper Amplitude reference in [Table 4-4 on page 154](#).

NOTE Under these analyzer conditions, the sweep time is 1.7 seconds. Therefore, the marker amplitude updates are fairly slow when adjusting the synthesizer output power.

5. Now that the reference has been established in step 4, adjust the synthesized sweeper power level and the analyzer reference level according to [Table 4-4 on page 154](#). (The synthesized sweeper output power and the analyzer's reference level will be changed in 10 dB steps.)
6. On the analyzer, press **Single**, wait for a sweep to finish, and then press **Peak Search**, **Marker**, **Delta**.
7. For each new synthesized sweeper power level and analyzer reference level change, press the following keys on the analyzer:

Single

Peak Search

Record the Analyzer Marker Amplitude reading in [Table 4-4](#).

Table 4-4 Reference Level Accuracy Worksheet (Log Mode)

Analyzer Reference Level		Synthesized Sweeper Amplitude (dBm)	Minimum (dB)	Analyzer Marker Δ Amplitude (dB)	Maximum (dB)
dBm	dBmV				
-30	21.76	Reference = _____	0 (Reference)	0 (Reference)	0 (Reference)
-20	31.76	Reference + (10 dB)	8.60		11.40
-10	41.76	Reference + (20 dB)	18.60		21.40
-40	11.76	Reference + (-10 dB)	-11.40		-8.60
-50	1.76	Reference + (-20 dB)	-21.40		-18.60
-60	-8.24	Reference + (-30 dB)	-31.40		-28.60
-70	-18.24	Reference + (-40 dB)	-42.0		-38.0

Linear Mode Procedure

1. Set the power level on the synthesized sweeper to -30 dBm by pressing **Power Level**, -30, **dBm**.
2. Set the analyzer by pressing the following keys:
Sweep, Sweep (Cont)
AMPLITUDE, More, Y Axis Units, dBm (50 Ω Input)
AMPLITUDE, -30, dBm (50 Ω Input)
AMPLITUDE, More, Y Axis Units, dBmV (75 Ω Input)
AMPLITUDE, +21.76, dBmV (75 Ω Input)
Scale Type (Lin)
3. Adjust the amplitude on the synthesized sweeper until the marker amplitude on the analyzer reads -30 dBm +/- 0.10 dB. Enter the synthesized sweeper power level as the Synthesized Sweeper Amplitude reference in [Table 4-5 on page 155](#).

NOTE Under these analyzer conditions, the sweep time is 1.7 seconds. Therefore, the marker amplitude updates are fairly slow when adjusting the synthesizer output power.

4. Now that the reference has been established in step 4, adjust the synthesized sweeper power level and the analyzer reference level according to [Table 4-5 on page 155](#) (The synthesized sweeper output power and the analyzer's reference level will be changed in 10 dB steps.)
5. On the analyzer, press **Single**, wait for a sweep to finish, and then press **Peak Search, Marker, Delta**.
6. For each new synthesized sweeper power level and analyzer reference level change,

press the following keys on the analyzer:

**Single
Peak Search**

Record the Analyzer Marker Amplitude reading in [Table 4-5](#)

Table 4-5 Reference Level Accuracy Worksheet (Linear Mode)

Analyzer Reference Level		Synthesized Sweeper Amplitude (dBm)	Minimum (dB)	Analyzer Marker Δ Amplitude (dB)	Maximum (dB)
dBm	dBmV				
-30	21.76	Reference = _____	0 (Reference)	0 (Reference)	0 (Reference)
-20	31.76	Reference + (10 dB)	8.60		11.40
-10	41.76	Reference + (20 dB)	18.60		21.40
-40	11.76	Reference + (-10 dB)	-11.40		-8.60
-50	1.76	Reference + (-20 dB)	-21.40		-18.60
-60	-8.24	Reference + (-30 dB)	-31.40		-28.60
-70	-18.24	Reference + (-40 dB)	-42.0		-38.0

Resolution Bandwidth Switching Uncertainty

Test Limits

Resolution Bandwidth	Minimum (dB)	Maximum (dB)
1 kHz	0 (Ref)	0 (Ref)
3 kHz	-0.3 dB	0.3 dB
10 kHz	-0.3 dB	0.3 dB
30 kHz	-0.3 dB	0.3 dB
100 kHz	-0.3 dB	0.3 dB
300 kHz	-0.3 dB	0.3 dB
1 MHz	-0.3 dB	0.3 dB
3 MHz	-0.3 dB	0.3 dB
5 MHz	-0.6 dB	0.6 dB

Test Description

To measure the resolution-bandwidth switching uncertainty, an amplitude reference is taken with the resolution bandwidth set to 1 kHz. The resolution bandwidth is changed to settings between 5 MHz and 3 kHz and the amplitude variation is measured at each setting using the marker delta function and compared to the specification. The span is changed as necessary to maintain approximately the same aspect ratio.

No equipment required for analyzer models E4401B and E4411B.

Item	Critical Specifications (for this test)	Recommended Agilent Model
Cables		
BNC, 9 inch		10502A
Adapter		
Type N to BNC		1250-0780 or 1250-1476

Figure 4-5 Equipment Setup

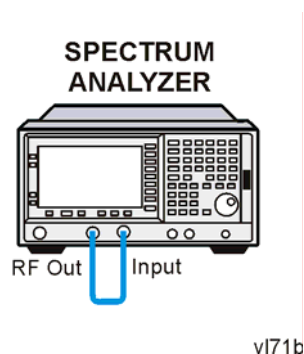

Procedure

NOTE The 50 MHz reference output will automatically be switched internally on the E4401B and E4411B and will not require any external connections. All other ESA analyzers require that the AMPTD REF OUT be connected to the INPUT to perform this test.

1. Press **System, Power On/Preset, Preset Type** (Factory), **Preset** on the analyzer. Wait for the preset routine to finish. Set the analyzer by pressing the following keys:

Input/Output, Amptd Ref (On) (E4401B and E4411B)

Input/Output, Amptd Ref Out (On) (E4402B, E4403B, E4404B, E4405B, E4407B, and E4408B).

Connect a cable from the **AMPTD REF OUT** to the **INPUT 50 Ω** , as shown in [Figure 4-5](#) (E4402B, E4403B, E4404B, E4405B, E4407B, and E4408B).

FREQUENCY, 50, MHz

SPAN, 50, kHz

AMPLITUDE, More, Y Axis Units, dBm (75 Ω Input only)

AMPLITUDE, -20, dBm

AMPLITUDE, Scale/Div, 1, dB

BW/Avg, Res BW, 1, kHz

Video BW, 1, kHz

2. Press **AMPLITUDE** and use the knob to adjust the reference level until the signal appears five divisions (mid-screen) below the reference level. Press the following keys on the analyzer:

Peak Search

Marker, Delta

FREQUENCY, Signal Track (On)

3. Set the analyzer Resolution Bandwidth and Span according to [Table 4-6 on page 158](#).
4. Press **Peak Search**, then record the Δ Mkr 1 amplitude reading in [Table 4-6](#).
5. Repeat step 3 and 4 for each of the remaining resolution bandwidth and span settings listed in [Table 4-6](#). The Δ Mkr 1 amplitude reading should be within the range indicated

in the table “Test Limits” on page 156.

Table 4-6 Resolution Bandwidth Switching Uncertainty Worksheet

Resolution Bandwidth Setting	SPAN Setting	Δ Mkr 1 Amplitude Reading
1 kHz	50 kHz	0 (Ref)
3 kHz	50 kHz	
10 kHz	50 kHz	
30 kHz	500 kHz	
100 kHz	500 kHz	
300 kHz	5 MHz	
1 MHz	10 MHz	
3 MHz	10 MHz	

Scale Fidelity

Test Limits

dB from Reference Level	Minimum (dB)	Maximum (dB)
-4	-1.0	1.0
-16	-1.4	1.4
-28	-1.4	1.4
-40	-1.4	1.4
-52	-1.4	1.4
-64	-2.0	2.0

Test Description

A 50 MHz CW signal is applied from a synthesized sweeper to the input of the analyzer. The source is adjusted for a response at the reference level. The synthesized sweeper amplitude is adjusted to achieve a nominal amplitude below the reference level. The analyzer's amplitude marker is compared to the actual source change to determine the scale fidelity error. Most of the error is the source's output attenuator inaccuracy from the synthesized sweeper.

Item	Critical Specifications (for this test)	Recommended Agilent Model
Signal Sources		
Synthesized Sweeper	Output Level Accuracy 0 to -15 dBm: ± 1.0 dB -16 dBm to -63 dBm: ± 1.4 dB ≤ -64 dBm: ≥ 2.0 dB	8340A/B or 836XX Series
Adapters		
Type-N (m), to BNC (f)		1250-1476
Cables		
Type-N, 152-cm (60-in)		11500D
BNC, 122-cm (48-in)		10503A
Additional Equipment for 75-Ohm Input		
Pad, minimum loss		11852B
Type-N (f), to BNC (m)		1250-1534

Figure 4-6 Equipment Setup

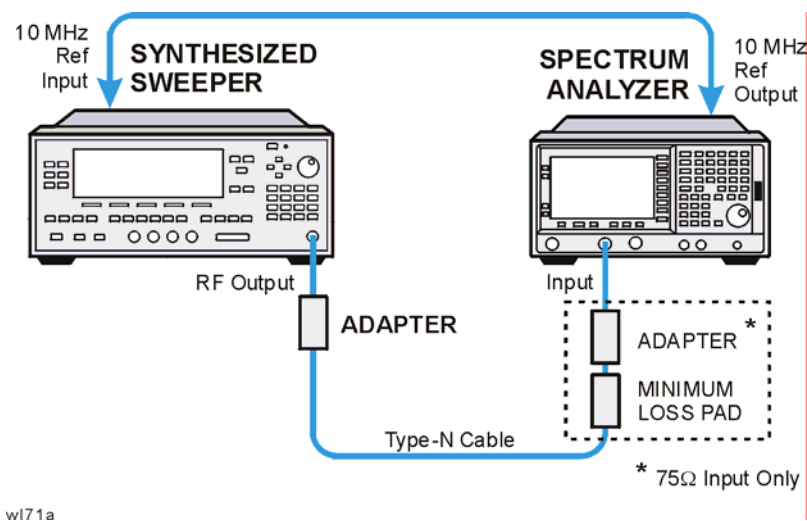

Procedure

1. Connect the equipment as shown in [Figure 4-6](#).
2. Preset the synthesized sweeper. Set the synthesized sweeper controls as follows:
 - CW, 50, MHz**
 - Power Level, 0, dBm (50 Ω Input)**
 - Power Level, 4, dBm (75 Ω Input)**
3. Press **System, Power On/Preset, Preset Type (Factory), Preset** on the analyzer, then wait for the preset routine to finish. Press **System, Alignments, Auto Align, Off**. Set the analyzer by pressing the following keys:
 - FREQUENCY, Center Freq, 50, MHz**
 - SPAN, 45, kHz**
 - AMPLITUDE, Attenuation, 10, dB**
 - BW/Avg, Res BW, 3, kHz**
 - Video BW, 1, kHz**
 - Peak Search**
4. Adjust the amplitude on the synthesized sweeper until the marker amplitude on the analyzer reads 0 dBm \pm 0.10 dB. Record the synthesized sweeper output level as the reference in [Table 4-7 on page 161](#).

NOTE *75 Ω Input only.* Adjust the synthesized sweeper amplitude until the analyzer's marker reads 48.8 dBmV \pm 0.10 dB.

5. On the analyzer, press the following keys:

- Single**
- Peak Search**
- Marker, Delta**

6. Record the marker delta reading in [Table 4-7](#). At each new synthesized sweeper power level, press **Single**, **Peak Search**, and record the marker amplitude level.

Table 4-7 Scale Fidelity Worksheet

Synthesized Sweeper Level	Minimum (dB)	Marker Level (dB)	Maximum (dB)
Reference=_____	0 (Reference)		0 (Reference)
Reference -4 dB	-5.0		-3.0
Reference -16 dB	-17.40		-15.60
Reference -28 dB	-29.40		-26.60
Reference -40 dB	-41.40		-38.60
Reference -52 dB	-53.40		-50.60
Reference -64 dB	-66.0		-62.0

Second Harmonic Spurious Responses

Test Limits

Model Number	Maximum
E4401B	-55 dBc
E4402B	-55 dBc
E4403B	-50 dBc
E4404B	-55 dBc
E4405B	-55 dBc
E4407B	-55 dBc
E4408B	-50 dBc
E4411B	-55 dBc

Test Description

To test second harmonic distortion, a 50 MHz low pass filter is used to filter the source output, ensuring that harmonics read by the analyzer are internally generated and not coming from the source. The source power and input attenuation on the analyzer are adjusted so -20 dBm is the power level at the first mixer.

Item	Critical Specifications (for this test)	Recommended Agilent Model
Signal Sources		
Synthesized Sweeper		8340A/B or 836XX Series
Miscellaneous		
50 MHz Low pass filter	Rejection at 80 MHz: >60 dB	0955-0306
Adapters		
(2) Type-N (m) to BNC (f)		1250-1476
BNC (f) to BNC (f)		1250-0080
Type-N (f), to APC 3.5(f)		1250-1745
Cables		
(2) BNC, 122-cm (48-in)		10503A

Item	Critical Specifications (for this test)	Recommended Agilent Model
Additional Equipment for 75 Ω Input		
Pad, minimum loss		11852B
Type-N (f), to BNC (m)		1250-1534

Figure 4-7 Equipment Setup

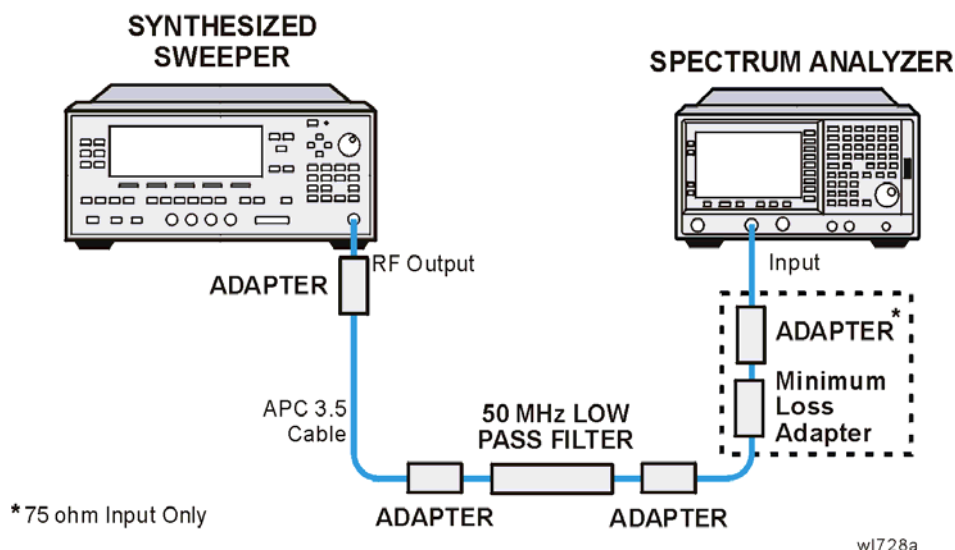

Procedure

1. Connect the equipment as shown in [Figure 4-7](#).
2. Set the synthesized sweeper controls as follows:

Frequency, 40, MHz
POWER LEVEL, -10, dBm (50 Ω Input only)
POWER LEVEL, -4.3, dBm (75 Ω Input only)

NOTE *75 Ω Input only.* Connect the minimum loss adapter between the low pass filter and 75 Ω Input.

3. Press **System, Power On/Preset, Preset Type (Factory), Preset** on the analyzer. Wait for the preset routine to finish.
Set the analyzer by pressing the following keys:

FREQUENCY, Center Freq, 40, MHz
SPAN, 1, MHz
AMPLITUDE, -10, dBm (50 Ω Input only)
AMPLITUDE, 44, dBmV (75 Ω Input only)
Attenuation (Man), 10, dB

BW/Avg, Res BW, 30, kHz

4. Adjust the synthesized sweeper power level to place the peak of the signal at the reference level.
5. Set the analyzer by pressing the following keys:

SPAN, 50, kHz

BW/Avg, Res BW, 1, kHz

Video BW, 100, Hz

6. Wait for two sweeps to finish, then press the following analyzer keys:

Peak Search

Mkr →

Mkr → CF Step

Marker, Delta

FREQUENCY

7. Press the $\hat{\uparrow}$ key on the analyzer to step to the second harmonic (at 80 MHz). Press **Peak Search**. The marker delta amplitude reading should be less than the Maximum value listed in the Test Limits Table.

Tracking Generator Level Flatness: Models E4401B and E4411B, Options 1DN and 1DQ

Test Limits

	Maximum	Maximum
Flatness \leq 10 MHz, 50 Ω	-2.5 dB	2.5 dB
Flatness $>$ 10 MHz, 50 Ω	-2.0 dB	2.0 dB
Flatness $>$ 10 MHz, 75 Ω	-3.0 dB	3.0 dB
Flatness $>$ 10 MHz, 75 Ω	-2.5 dB	2.5 dB

Test Description

A calibrated power sensor is connected to the tracking generator output to measure the power level at 50 MHz. The power meter is set for REL mode so that future power level readings are in dB relative to the power level at 50 MHz. The tracking generator is then stepped to several frequencies throughout its range. The output power difference relative to the power level at 50 MHz is measured at each frequency and recorded. Analyzers with 75 Ω tracking generators are only tested from 1 MHz to 1500 MHz.

Item	Critical Specifications (for this test)	Recommended Agilent Model
Meters		
Power Meter		438A or E4418A, E4419A
RF Power Sensor	Frequency Range: 100 kHz to 1.5GHz	8482A
Cables		
BNC, 122-cm (48-in) (2)		10503A
Additional Equipment for 75 Ω Input		
75 Ω Power Sensor	Frequency Range: 1 MHz to 1.5GHz	8483A
Type-N (f) to BNC (m), 75 Ω Adapter		1250-1534

Figure 4-8 Equipment Setup

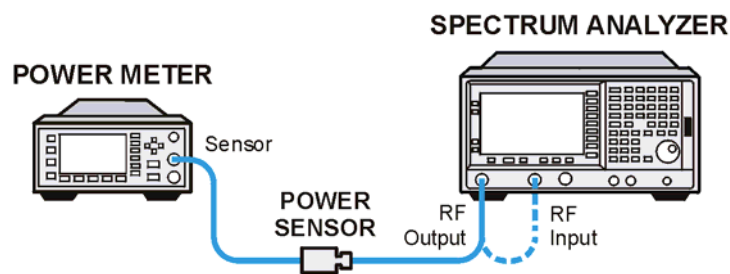

wi712a

Procedure

1. Calibrate the tracking generator by pressing **System, Alignments, Align Now, TG**. Connect the RF Out to the Input when prompted.
2. Press **System, Power On/Presets, Preset Type (Factory), Preset** on the analyzer, then wait for the preset routine to finish. Set the analyzer by pressing the following keys:
 - FREQUENCY, Center Freq, 50, MHz**
 - CF Step, 500, MHz**
 - SPAN, Zero Span**
 - Source, Amplitude (On), 0, dBm (50 Ω RF Output only)**
 - Source, Amplitude (On), 42.76, dBmV (75 Ω RF Output only)**
3. Zero and calibrate the power meter and RF power sensor. Make sure the power meter is reading out in dBm. Enter the power sensor 50 MHz cal factor into the power meter.

NOTE 75 Ω RF Out only: Zero and calibrate the 75 Ω power sensor.

4. Connect the power sensor to the RF Out on the analyzer as shown in [Figure 4-8](#).

NOTE 75 Ω RF Out only: Connect the 75 Ω power sensor through an adapter to the RF Out 75 Ω .

5. Press REL on the power meter. The power meter readout amplitudes are now relative to the power level at 50 MHz.
6. Set the analyzer center frequency to 100 kHz by pressing **FREQUENCY, 100, kHz**.

NOTE 75 Ω RF Out only: Set the analyzer center frequency to 1 MHz.

7. Enter the appropriate power sensor Cal Factor for the test frequency into the power meter as indicated on the label of the power sensor.
8. Record the power level displayed on the power meter as the Level Flatness in [Table 4-8](#).

9. Repeat steps 7 through 8 to measure the flatness at each center frequency setting listed in Table 4-8. The \uparrow may be used to tune to center frequencies above 500 MHz.

NOTE *75 Ω RF Out only:* Repeat steps 5 through 7 to measure the flatness at the frequencies above 1 MHz listed in Table 4-8.

Table 4-8 Tracking Generator Level Flatness Worksheet

Center Frequency	Level Flatness (dB)
100 kHz or 1 MHz ^a	
5 MHz	
40 MHz	
50 MHz	0 (Ref)
80 MHz	
500 MHz	
1000 MHz	
1500 MHz	

- a. This frequency is 100 kHz for analyzers with 50 Ω tracking generators, and 1 MHz for analyzers with 75 Ω tracking generators.

Tracking Generator Level Flatness: E4402B, E4403B, E4404B, E4405B, E4407B and E4408B, Option 1DN

Test Limits

	Maximum	Maximum
Flatness \leq 10 MHz	-3.5 dBm	+3.5 dBm
Flatness $>$ 10 MHz	-2.5 dBm	-2.5 dBm

Test Description

A calibrated power sensor is connected to the tracking generator output to measure the power level at 50 MHz. The power meter is set for REL mode so that future power level readings are in dB relative to the power level at 50 MHz. The tracking generator is then stepped to several frequencies throughout its range. The output power difference relative to the power level at 50 MHz is measured at each frequency and recorded.

Item	Critical Specifications (for this test)	Recommended Agilent Model
Meters		
Power Meter		438A or E4418A, E4419A
RF Power Sensor	Frequency Range: 100 kHz to 3.0 GHz	8482A
Adapters		
Type-N (f) to BNC (m), 75-Ohm		1250-1534
Cables		
(2) BNC, 122-cm (48-in)		10503A

Figure 4-9 Equipment Setup

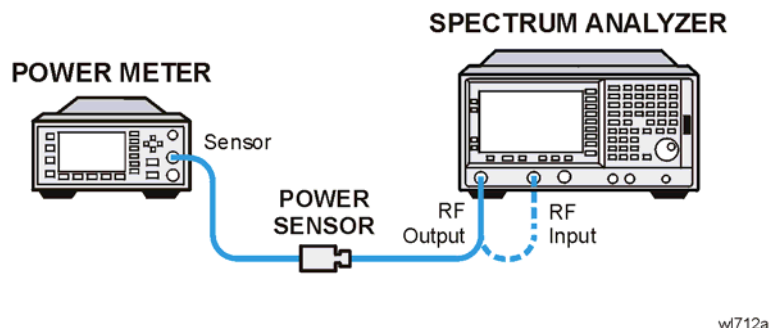

Procedure

1. Calibrate the tracking generator by pressing **System, Alignments, Align Now, TG**. Connect the RF OUT to the RF INPUT when prompted.
2. Press **System, Power On/Preset, Preset Type (Factory), Preset** on the analyzer, then wait for the preset routine to finish. Set the analyzer by pressing the following keys:
 - FREQUENCY, Center Freq, 50, MHz**
 - CF Step, 100, MHz**
 - SPAN, Zero Span**
 - Source, Amplitude (On), -20, dBm**
 - System, Alignments, Auto Align, Off**
3. Zero and calibrate the power meter and power sensor. Make sure the power meter is reading out in dBm. Enter the power sensor 50 MHz cal factor into the power meter.
4. Connect the power sensor to the RF Out on the analyzer as shown in [Figure 4-9](#).
5. Press REL on the power meter. The power meter readout amplitudes are now relative to the power level at 50 MHz.
6. Set the analyzer center frequency to 100 kHz by pressing **FREQUENCY, 100, kHz**.
7. Enter the appropriate power sensor Cal Factor for the test frequency into the power meter as indicated on the label of the power sensor. This must be done at each test frequency.
8. Record the power level displayed on the power meter as the Level Flatness in [Table 4-9 on page 170](#).
9. Repeat steps 5 through 7 to measure the flatness at each center frequency setting listed in [Table 4-9](#). The \uparrow may be used to tune to center frequencies above 500 MHz.
10. Press **System, Alignments, Auto Align, On**.

Table 4-9 Tracking Generator Level Flatness Worksheet

Center Frequency	Level Flatness (dB)
100 kHz	
5 MHz	
40 MHz	
50 MHz	0 (Ref)
80 MHz	
500 MHz	
1000 MHz	
1500 MHz	
2000 MHz	
2300 MHz	
2500 MHz	
2700 MHz	
3.0 GHz	

Numerics

1xEV-DO error messages
13001 to 13100, [81](#), [83](#)

A

Agilent Technologies URL, [2](#)
amplitude accuracy test, [106](#)
option 1DS, [110](#)
amplitude linearity test, [119](#)

C

cdma2000 error messages
10801 to 10900, [75](#)
cdmaOne error messages
10951 to 10975, [76](#)
command error messages, [31](#), [36](#)

D

DANL test, [111](#)
device-specific error messages
-399 to -300, [31](#), [33](#)
64 to 799, [31](#), [39](#)
displayed average noise level. See
DANL, [111](#)

E

equipment
functional tests, [101](#)
warm-up time, [100](#)
error history, [29](#)
error messages, [32](#)
>10,000 (measurement
application), [31](#), [53](#)
-199 to -100 (command), [31](#)
1xEV-OD (13001 to 13100), [81](#),
[83](#)
-299 to -200 (execution), [31](#)
-399 to -300 (device-specific), [31](#)
-499 to -400, [31](#)
64 to 799 (device-specific), [31](#)
cdma2000 (10801 to 10900), [75](#)
cdmaOne (10951 to 10975), [76](#)
command (-199 to -100), [31](#), [36](#)
device-specific (-399 to -300), [31](#),
[33](#)
device-specific (64 to 799), [31](#),
[39](#)
empty error queue, [32](#)
example, [30](#)
execution (-299 to -200), [31](#)
format, [30](#)
GSM/EDGE (10601 to 10700),
[71](#)
measurement application
(>10,000), [31](#), [53](#)

NADC (10901 to 10925), [76](#)
noise figure (12000 to 12999), [78](#)
PDC (10926 to 10950), [76](#)
personality option, [31](#), [53](#)
phase noise (10524 to 10561), [69](#)
phase noise (10976 to 11000), [77](#)
power suite (10008 to 10517), [53](#)
query, [31](#), [32](#)
types, [31](#)
viewing messages in queue, [29](#)
W-CDMA (10701 to 10800), [74](#)

error queues

capacity, [29](#)
clearing, [29](#)
empty message, [32](#)
front panel, [29](#)
overflow handling, [29](#)
remote interface (SCPI), [29](#)
SCPI remote interface, [29](#)
types, [29](#)
viewing entries, [29](#)

errors

0, [32](#)
10008 to 10517 (power suite), [53](#)
10524 to 10561 (phase noise), [69](#)
10601 to 10700 (GSM/EDGE),
[71](#)
10701 to 10800 (W-CDMA), [74](#)
10801 to 10900 (cdma2000), [75](#)
10901 to 10925 (NADC), [76](#)
10926 to 10950 (PDC), [76](#)
10951 to 10975 (cdmaOne), [76](#)
10976 to 11000 (phase noise), [77](#)
12000 to 12999 (noise figure), [78](#)
13001 to 13100 (1xEV-OD), [81](#),
[83](#)
-199 to -100 (command), [36](#)
-299 to -200 (execution), [33](#)
-399 to -300 (device-specific), [33](#)
-499 to -400, [32](#)
64 to 799 (device-specific), [39](#)
execution errors, [31](#), [33](#)

F

flatness, [142](#)
frequency response, [142](#)
test description, [142](#)
frequency readout accuracy test,
[113](#)
frequency response, [142](#)
flatness, [142](#)
test description, [142](#)
frequency response (flatness) test,
[115](#)
front panel
error queue characteristics, [29](#)
front panel error queue, [29](#)

functional testing
introduction, [98](#)
performance verification, [98](#)
functional tests
before performing, [100](#)
equipment list, [101](#)
introduction, [97](#)
vs performance verification
tests, [98](#)
warm-up time, [100](#)
See also individual functional
tests, [97](#)

G

GSM/EDGE error messages
10601 to 10700, [71](#)

I

informational messages, [28](#)
descriptions, [84](#)
display location, [84](#)

M

measurement application error
messages
>10,000, [31](#), [53](#)
messages
error, [32](#)
informational, [84](#)
status, [89](#)

N

NADC error messages
10901 to 10925, [76](#)
noise figure error messages
12000 to 12999, [78](#)

P

PDC error messages
10926 to 10950, [76](#)
performance verification tests vs
functional tests, [98](#)
personality error messages, [31](#),
[53](#)
phase noise error messages
10524 to 10561, [69](#)
10976 to 11000, [77](#)
pop-up messages, [28](#)
power suite error messages
10008 to 10517, [53](#)

Q

queries
error messages, [31](#), [32](#)

R

remote interface (SCPI) error
queue, [29](#)

S

SCPI interface error queue, [29](#)
second harmonic distortion test,
[122](#)
status messages, [28](#)
descriptions, [89](#)
display location, [89](#)

T

test descriptions
frequency response, [142](#)
tests. See functional tests

U

URL (Agilent Technologies), [2](#)
user error messages, [28](#)

W

W-CDMA error messages
10701 to 10800, [74](#)