

ARKIV

4220

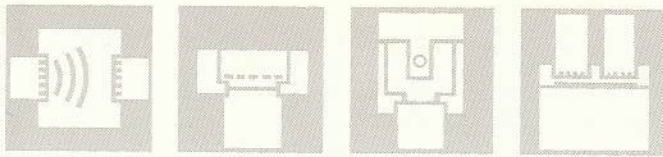

Aalborg Universitetscenter
Institut for Elektroniske Systemer
 Laboratoriet
 Strandvejen 19
 9000 Ålborg

MICROPHONE CALIBRATION

for accurate Sound Measurements



**Calibration Chart for
Condenser Microphone
Cartridge Type 4133**

Serial No. 33376

Open Circuit Sensitivity at 750 mm Hg
 -36.6 dB re. 1 V per μbar at 1000 $\mu\text{m/s}$

Open Circuit Correction Factor
 $K_{oc} = -1.0 \text{ dB}$

Capacitance
 $C = 10.3 \text{ pF}$

Leakage Resistance (measured at 25% relative humidity)
 $> 10^{12} \Omega$

Frequency Response Characteristics:
 The upper curve is the open circuit free field (free field) response of the microphone cartridge with protective grid. Sound waves perpendicular to the diaphragm (see Fig. 1). The lower curve is the open circuit pressure response measured with electrostatic actuator.

*) Subtract the gain of the preamplifier (see back of this chart) from K_{oc} to get the actual correction factor K_c . Give instructions manual for the use of K_c .
 1 $\mu\text{bar} = 10 \text{ dynes/cm}^2 = 10^{-6} \text{ bar}$.

Conditions of Test:
 Frequency: 250 Hz
 Atmospheric Pressure: 755.3 mm Hg
 Relative Humidity: 22.1%
 Temperature: 22.1 °C
 Date: 22.2.71 Signature: E. E.

Summarized Specifications
Outside Diameter:
 8.25 in (212 mm) with protective grid.
 8.26 in (212 mm) without protective grid.
Coupler Mounting Thread (grid thread):
 8.36 in (212 mm) SWS.

Frequency Response Characteristics:
 Frequency range which free-field response shall be flat within $\pm 2 \text{ dB}$:
Lower Limiting Frequency: 1.2 dB as determined by pressure equalization is between 1 Hz and 3 Hz.
Resonance Frequency: approx. 25 kHz (over-coupled).
Equivalent Air Volume at 1 atm, about 0.01 cm³.
Ambient Pressure: Influence on sensitivity approx. $\pm 0.1 \text{ dB}$ for $\pm 10\%$ pressure change.
Temperature Coefficient: between -50 and $+50^\circ\text{C}$. Less than $\pm 0.08 \text{ dB}/^\circ\text{C}$.
Relative Humidity: The influence of humidity does not exceed $\pm 1 \text{ dB}$ in the absence of condensation.
Dynamic Range: Sound Pressure Level below which the total harmonic distortion becomes less than 1% (24 dB).

Measuring Object: _____ Brüel & Kjær

Sign: _____ Date: _____ Potentiometer: _____ Zero Level: _____ D A B C lin.

Rectifier: _____ Lower Lim. Freq.: _____ Hz Writing Speed: _____ mm/sec. Paper Speed: _____ mm/sec. 171730

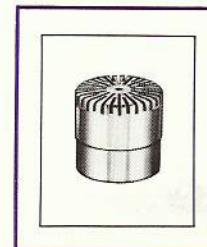



Introduction

Any sound measuring system, from the simple sound level meter to the complex, computerized monitoring or analyzing systems, must be accurately calibrated in order to provide meaningful results which can be used to improve the quality of a product or of our environment. Regular calibration checks will prove the stability of the system and will ensure that the requirements of the standards which apply to the measurements are fulfilled. Hence, measurements taken at different intervals can be used for comparison purposes.

B & K microphones are fully calibrated at the factory and delivered with an individual calibration chart giving all relevant data, but it will often be more practical to calibrate a whole measuring set-up, from microphone to read-out, using a known acoustical reference. For instance, when a sound signal is recorded on a tape recorder for later processing in the laboratory, a calibration signal recorded before the sound signal will provide an accurate reference for setting up the analysis system at playback. Also, before starting a frequency analysis, a reference signal is needed to calibrate the pen deflection on the level recorder.

Brüel & Kjær has more than thirty years' experience in the production of sound measuring equipment and has developed a wide variety of calibration systems, both for field and laboratory use.

This leaflet describes the different calibration methods available and how the B & K calibration equipment can be applied to obtain the required accuracy.

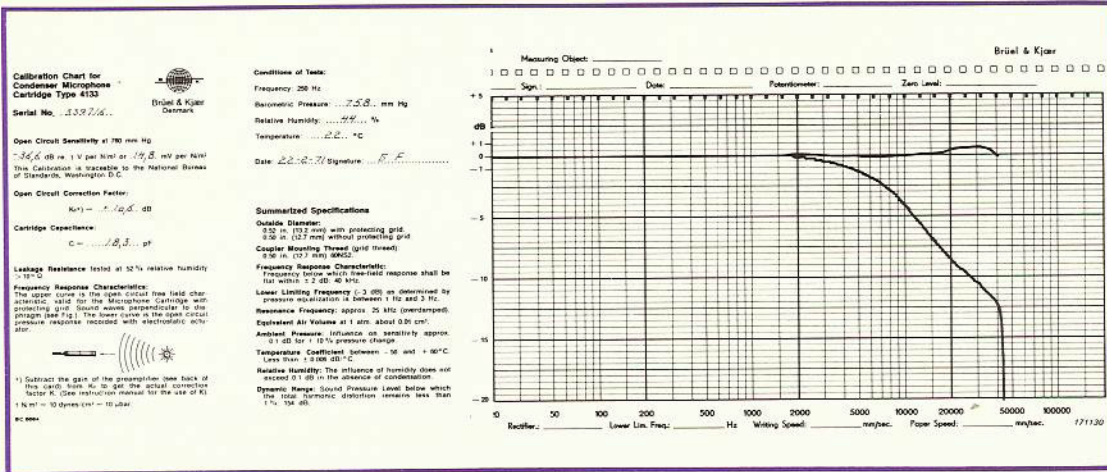

Typical calibration chart delivered with each B & K Condenser Microphone Cartridges

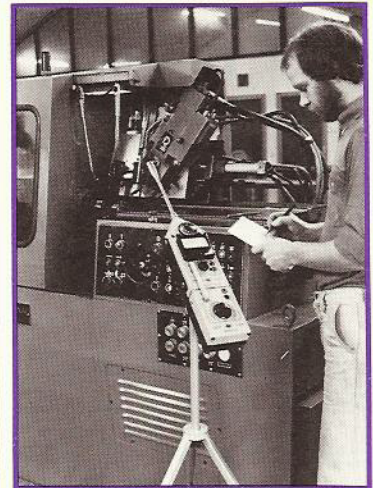

What to Calibrate?

Basically, microphone calibration involves measuring the absolute sensitivity at one frequency and the pressure frequency response at a single amplitude level. From the combination of the two, the operation of the microphone can be predicted for a wide range of applications. However, for some applications, other characteristics may be of interest, such as amplitude linearity at high sound pressure levels, phase response, transient response, and frequency response of the microphone in gases other than air or at pressures other than atmospheric.

For a complete sound measuring system, calibration is normally limited to sensitivity measurement at one frequency, although it may be desired in some cases to measure the frequency response as well.

The main methods for sensitivity calibration are the reciprocity method, the comparison method and the transfer method using a calibrated sound source. The so called "insert voltage" technique may be used in the three above calibration methods to obtain the microphone open-circuit sensitivity.

The microphone frequency response is normally measured using the electrostatic actuator method, which is also used for phase and transient response measurements. The electrostatic actuator gives the microphone pressure response. If the free-field response is of interest, the relevant free-field corrections should be added to the actuator characteristics. Alternatively, the free-field response may be measured in an anechoic room.

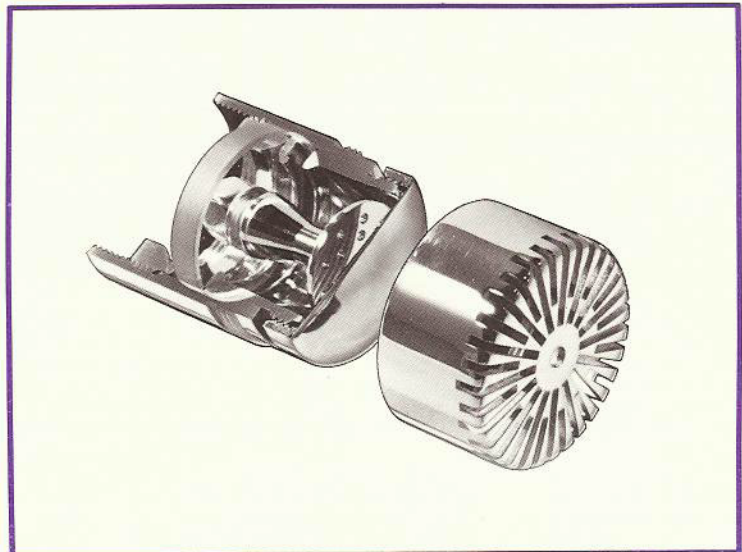



Microphone Sensitivity

Generally, the sensitivity of a microphone is measured in terms of open-circuit sensitivity. This is defined as the ratio of the microphone output voltage to the sound pressure acting on the diaphragm when the microphone is working into an infinite electrical impedance. One advantage of this definition is that, when the microphone is mounted on a preamplifier, it is a simple matter to derive the overall sensitivity of the assembly if the open-circuit sensitivity and the capacitance of the microphone are known together with the preamplifier attenuation and input capacitance.

Although a microphone is always used with a preamplifier, which does not have an infinite input impedance, the open-circuit sensitivity can be measured using the insert voltage technique which will be described later.

Several Degrees of Accuracy

The sensitivity of a microphone may be calibrated with different degrees of accuracy, depending on the use for which the microphone is intended. Basically, microphones may be divided into three groups, according to the accuracy with which they are calibrated:

primary standards, secondary standards and measurement microphones.

Primary standards are calibrated with the highest possible accuracy, using for example the reciprocity method. Primary standards are used to calibrate secondary standards which, in turn, are used to calibrate measurement microphones. Primary standards are also used to calibrate reference sound sources, such as the Pistonphone. These "transfer" standards are then used for the calibration of secondary standard microphones or complete sound measuring systems at one single frequency.

Besides the calibration of secondary or transfer standards, primary standard microphones are seldom used for continuous calibration work. They are carefully protected against the rigours of routine work so that they will develop a history of stable reference confirmed by annual certifications by external authorities.

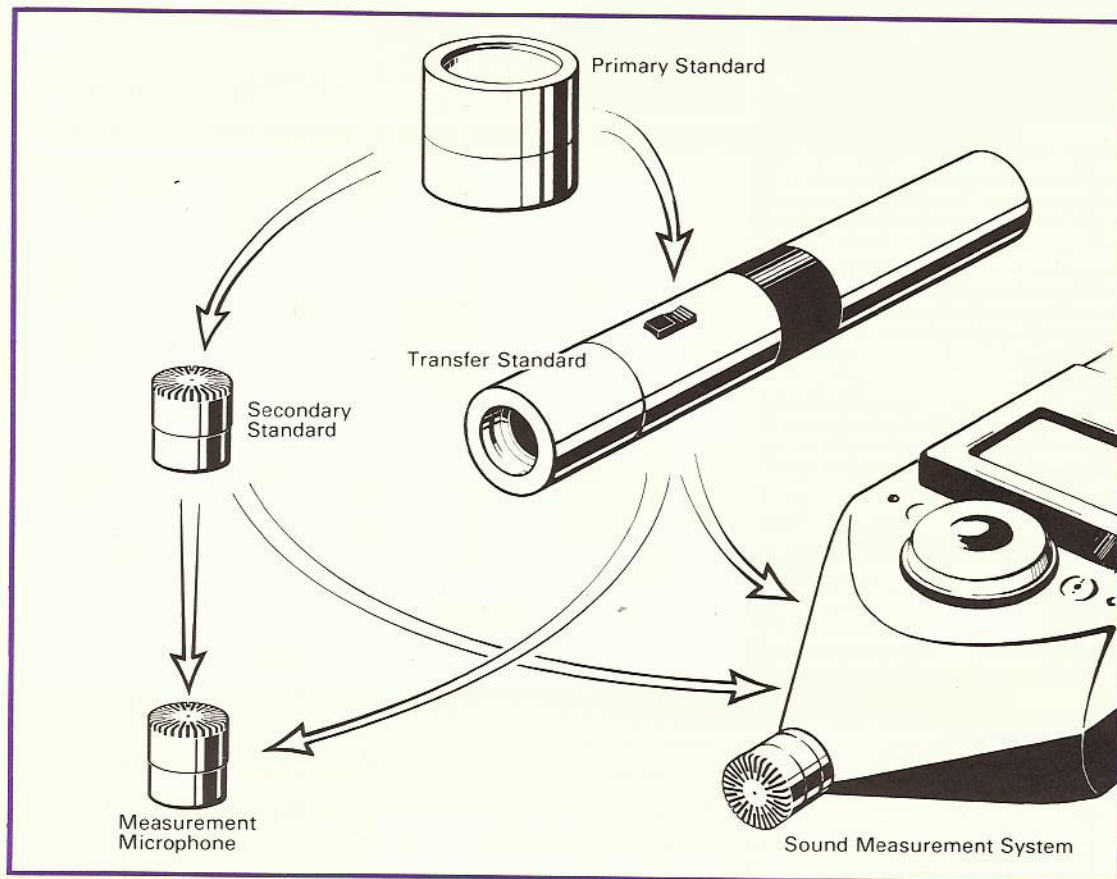

Standard Microphones

The most commonly used standard microphones are 1" condenser microphones which meet the Type L requirements of ANSI S1.12-1967, "Specifications for Laboratory Standard Microphones". These specifications, originating in the 1940s, were written around the only instrumentation condenser microphone then available, the Western Electric 640 AA, which has developed over the years a long history of stable operation.

In 1958, Brüel & Kjær introduced the 4132, later redesignated as Type 4144. When fitted with the

Coupler Adaptor Ring DB 0111, this microphone also meets or exceeds the ANSI Type L requirements. It, too, has built up a history of stable performance as a laboratory standard.

Recently developed, the B & K Type 4160 also meets the ANSI standards and is an exact equivalent of the 640 AA, having the same nominal sensitivity and equivalent volume. The ring providing the normalized front cavity is permanently mounted and ensures very low hydrogen leakage from the coupler in reciprocity calibration.



Type 4144 fitted with Coupler Adaptor Ring DB 0111



Type 4160, equivalent to WE 640 AA



Reciprocity Calibration

Reciprocity calibration is an absolute calibration method by which a highly accurate calibration is obtained without reference to a standard microphone or sound source. The method is described in IEC Recommendation 327 and 402 and in ANSI S1.10-1966. The accuracy obtained on the pressure sensitivity is estimated to be 0,05 dB.

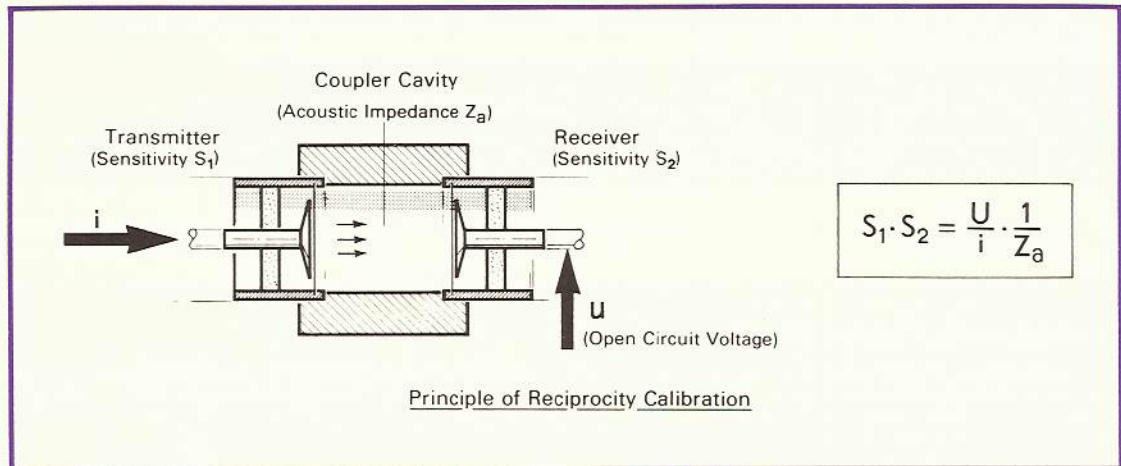

Principle

Two microphones, M_1 and M_2 , are acoustically coupled in a small closed cavity where M_1 is used as the transmitter and M_2 as the receiver. From the current through the transmitter microphone, the output voltage of the receiver microphone and the cavity volume, the product of the microphone sensitivities may be calculated. Using a third microphone, M_3 , in turn with M_1 and M_2 , three sensitivity products are obtained, from which the individual sensitivities are derived. Alternatively, use can be made of two microphones and an auxiliary sound source.

Since reciprocity calibration is used to measure the open-circuit sensitivity, the insert voltage technique must be used to compensate for the loading effect of the preamplifier.

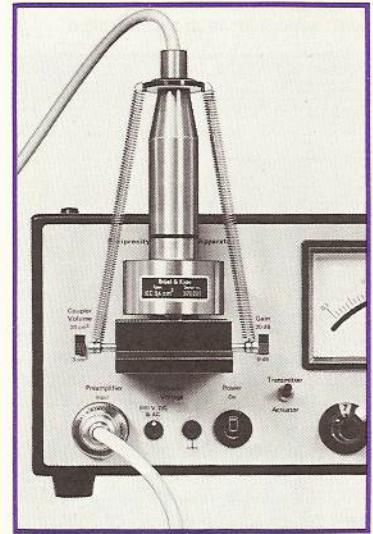
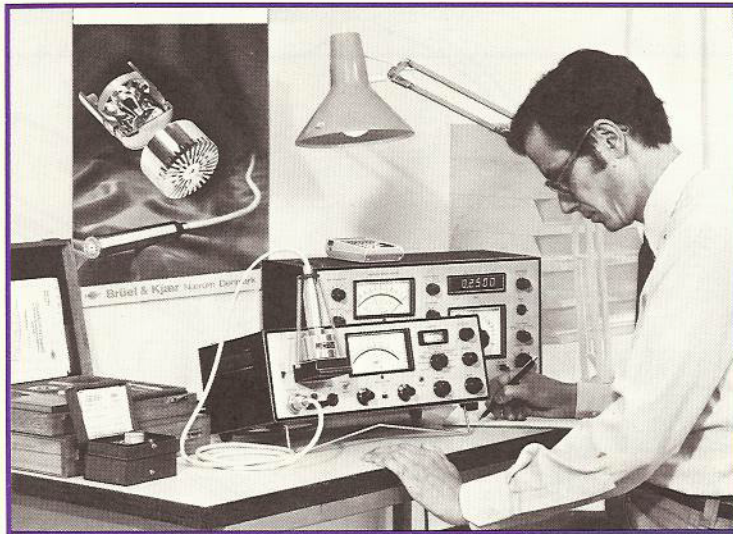

The Reciprocity Calibration Apparatus Type 4143

The 4143 is a high-precision laboratory instrument which makes sensitivity-product measurement a simple procedure. The only external equipment needed is a signal generator. After a few preliminary adjustments, the sensitivity product is obtained directly from the meter reading and the attenuator settings. To comply with IEC R 327, the standard corrections for heat conduction and capillary tubes must be applied together with corrections for deviation of cavity volume and static pressure from nominal values.

The 4143 is delivered with a comprehensive range of accessories, including the two normalized IEC couplers, a Condenser Microphone Type 4160, an Insert Voltage Preamplifier Type 2627 and Electrostatic Actuators UA 0023 and

UA 0033. The instrument is individually calibrated and is delivered with a calibration chart giving all relevant data and correction factors.

In addition to reciprocity calibration, the 4143 may be used for a wide range of calibration measurements:

- Comparison calibration of 1" and 1/2" microphones
- Reference Sound Source
- Frequency response measurements using the Electrostatic Actuator method
- Microphone equivalent volume measurement
- High-precision comparison of electrical signals
- Reciprocity and comparison calibration of accelerometers

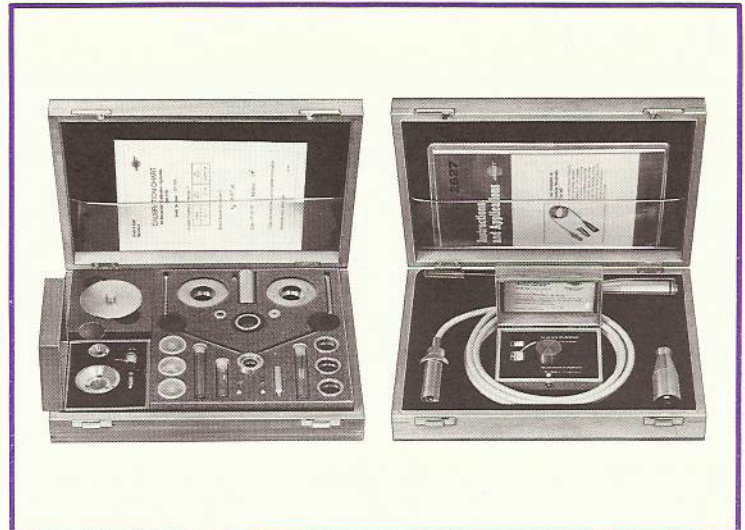



Comparison Calibration

Comparison calibration is the most widely known technique for transferring calibration from the standard to the unknown microphone. The microphone under test and a standard microphone are submitted to the same sound pressure and the sensitivity of the unknown microphone is derived from the two resulting output voltages. In practice, the method can be implemented in three different ways: in a coupler, in an anechoic room, or using a transfer standard.

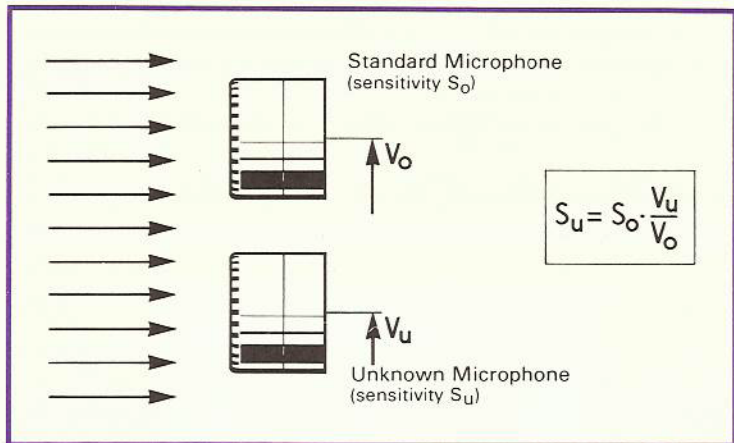

Comparison Calibration in Couplers

This type of calibration can be carried out in two ways. The first method is to use both the standard and the unknown microphones as receivers in a coupler where the sound pressure is created by some other source, as with the B & K High Pressure Microphone Calibrator Type 4221. The second method is to use one microphone (for example the standard) as sound transmitter and the other as the receiver. This is the case with the Reciprocity Calibration Apparatus Type 4143 for instance. The microphones are set up in the same way as for reciprocity calibration and their sensitivity product is measured. Since the sensitivity of the standard microphone is known, the sensitivity of the unknown can be derived from the sensitivity product.

Comparison Calibration in Anechoic Rooms

Calibration in anechoic rooms allows measurement of the microphone's free-field response. If the standard microphone has a flat frequency response over the frequency range of interest, it can be included in the compressor loop of the generator for automatic recording of the frequency response of the unknown microphone.

Comparison Calibration using a Transfer Standard

In this type of calibration, the standard and the unknown microphones are submitted in turn to the sound pressure delivered by a sound generating device, such as the B & K Pistonphone Type 4220. This method is used for the factory calibration of the B & K microphones.

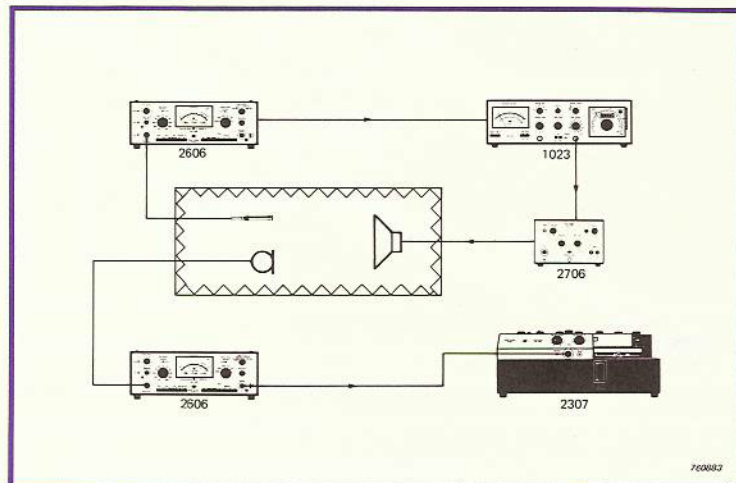

Set-up for Comparison Calibration in an Anechoic Room using a Compressor Loop

Free-field Corrections

Most microphone calibration methods give the microphone pressure response, i. e. the response of the microphone to the sound pressure actually acting on the diaphragm. However, when performing free-field measurements, the original sound field is affected, at higher frequencies, by the presence of the microphone, which results in an increased sound pressure at the microphone diaphragm. This pressure increment is called the free-field correction and should be applied to the microphone pressure response in order to obtain the microphone free-field response at a given angle of sound incidence. The free-field correction curves for the B & K microphones are given in the Microphone Handbook.

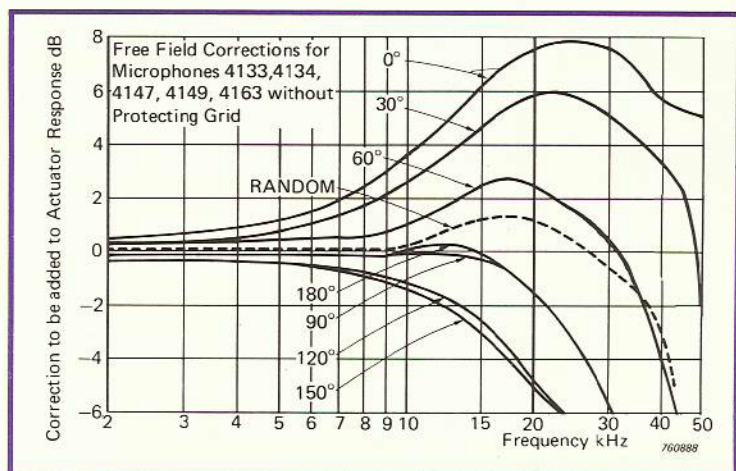
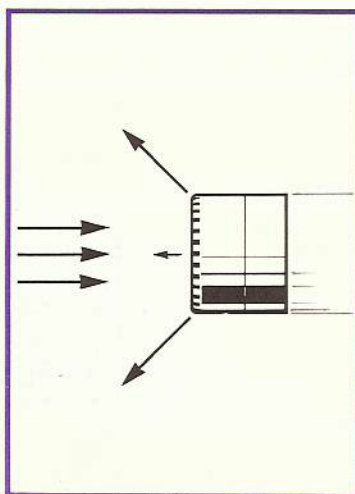

Example of free-field correction curves



Transfer Standards

Transfer standards are used for comparison calibration of microphones. They also provide a simple and accurate means of calibrating complete measuring systems, both in the field and in the laboratory.

Pistonphone Type 4220

The Pistonphone Type 4220 is a battery-operated, highly stable sound calibrator for both field and laboratory calibration. It operates at 250 Hz and produces a sound pressure level of 124 dB re 20 μ Pa. Calibration accuracy is $\pm 0,2$ dB. The sound pressure is produced in the cavity by two pistons moving in opposite phase. This arrangement, together with

careful cam design and machining, ensures very high stability and very low non-linear distortion.

Using an external DC voltage source, the Pistonphone can be operated over the frequency range 30 Hz to 320 Hz. The Pistonphone fits 1" microphones directly and is delivered with adaptors for 1/2", 1/4" and 1/8" microphones.

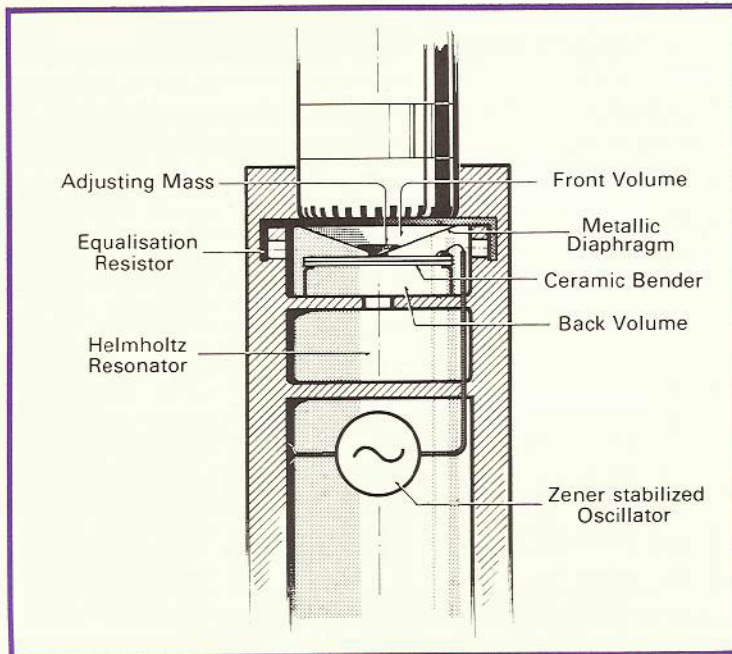
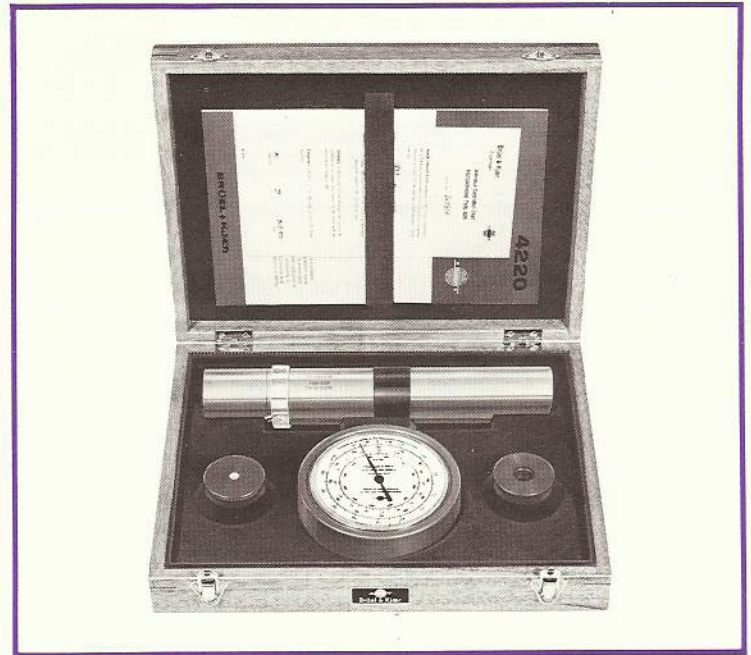
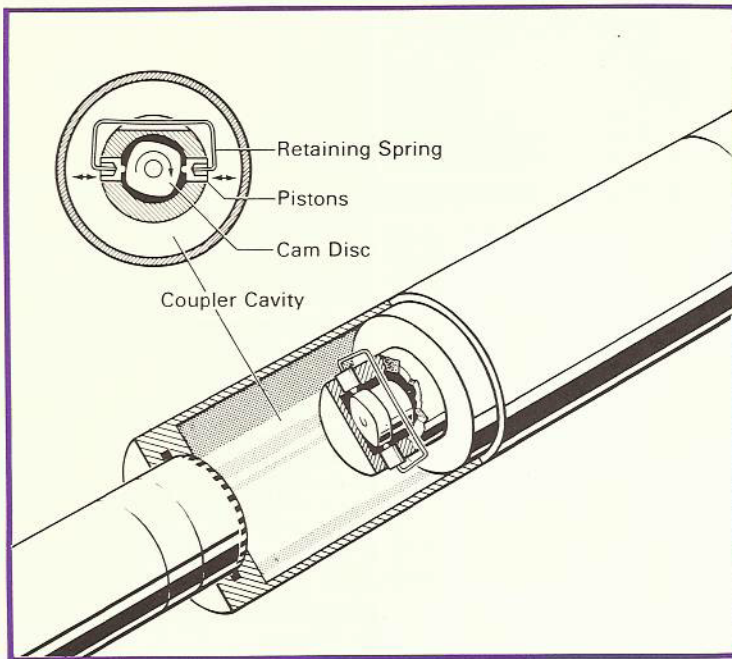

Sound Level Calibrator Type 4230

The Sound Level Calibrator Type 4230 is a portable sound source which vibrates a metallic diaphragm and creates the sound pressure in the cavity. The 4230 fits 1" microphones directly and is delivered with an adaptor for 1/2" microphones. Calibration level is 94 dB re. 20 μ Pa (≈ 1 Pa), with an accuracy of $\pm 0,25$ dB. A stabilized





Insert Voltage Technique

This technique, described in IEC R 327, allows measurement of the open-circuit sensitivity of a microphone, by compensating for the voltage loss due to the preamplifier input capacitance and internal attenuation.

The principle of the method is illustrated in the figure. The microphone is first submitted to a known sound pressure and the resulting output voltage is noted. The sound source is stopped, and a voltage at the same frequency — the insert voltage — is applied in series with the microphone. The insert voltage is adjusted until the output voltage from the microphone assembly is the same as it was using the sound source. The insert voltage divided by the applied sound pressure is then equal to the microphone open-circuit sensitivity. The voltage loss can be measured so that it can be taken into account in later measurements. Alternatively, the gain of the measuring system can be adjusted to compensate for the attenuation so that the meter reading corresponds to the open-circuit voltage.

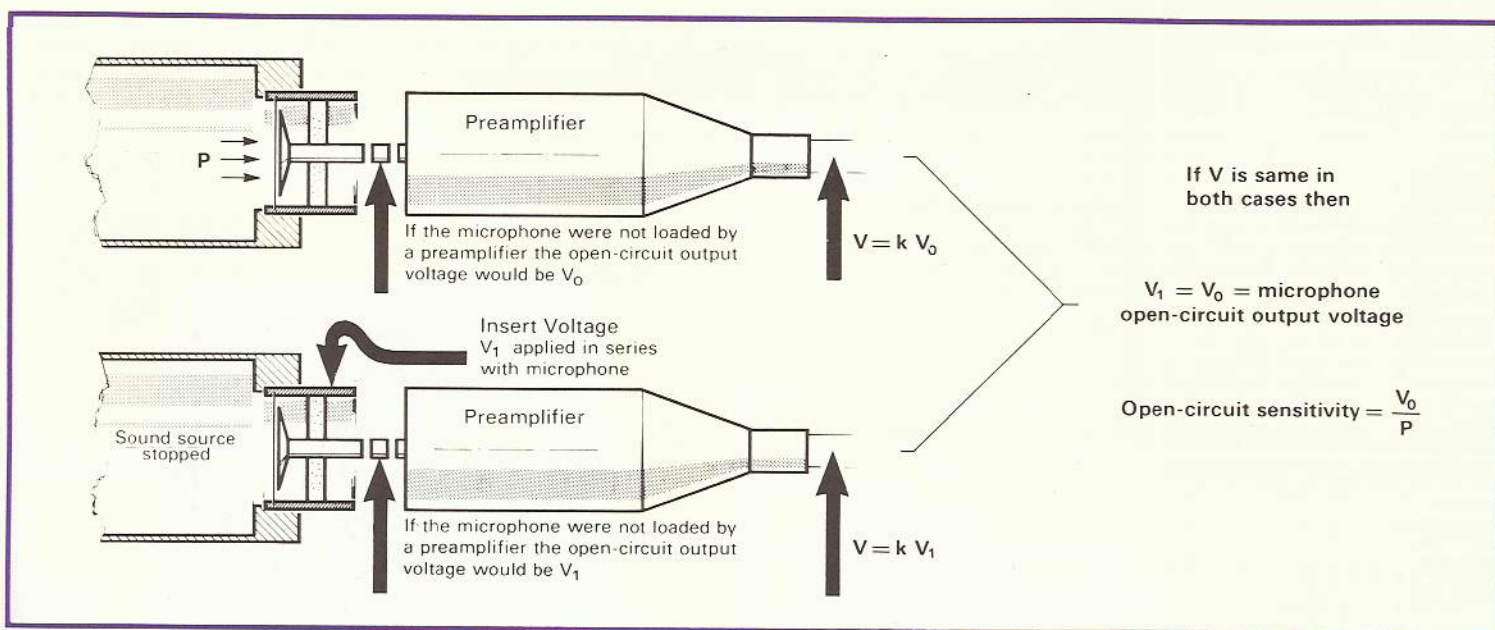

The B & K Insert Voltage Preamplifier Type 2627

The 1" Microphone Preamplifier Type 2627 has been designed primarily for calibration purposes. It features the normalized input configuration and can operate with either driven or grounded input shield in order to meet the different requirements of various calibration standards, and allows insert voltage calibration. Double screening ensures very low crosstalk between insert and signal lines.

Most newer B & K Measuring Amplifiers and Frequency Analyzers have a built-in insert voltage facility. The signal delivered by the internal reference oscillator (50 mV at 1000 Hz) can be fed to the insert line of the 2627. Alternatively, an external generator can be used if other levels or frequencies are required. However, Types 2608 and 2609 and all previous types require use of the Junction Box ZH 0007 and an external oscillator.

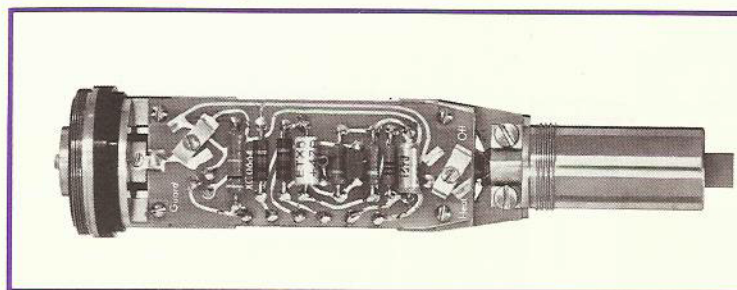

The input configuration of the 2627 conforms with the international calibration standards

Standard Microphone System

The Preamplifier Type 2627, together with a primary standard microphone and a precision voltmeter (e.g. B & K Measuring Amplifier Type 2606) allows a standard microphone system to be formed. Using the insert voltage technique, the system can be adjusted to indicate the microphone open circuit voltage.

Alternatively, an external voltage fed to the direct input of the 2606

can be adjusted to correspond to the microphone open circuit sensitivity (e.g. 48.7 mV for a microphone sensitivity of 48.7 mV/Pa). The voltage is then fed through the microphone and preamplifier to the 2606 fitted with an SPL meter scale, and the 2606 is adjusted to indicate 94 dB (1 Pa).

Such a standard microphone system will be used to calibrate secondary standards and transfer standards.

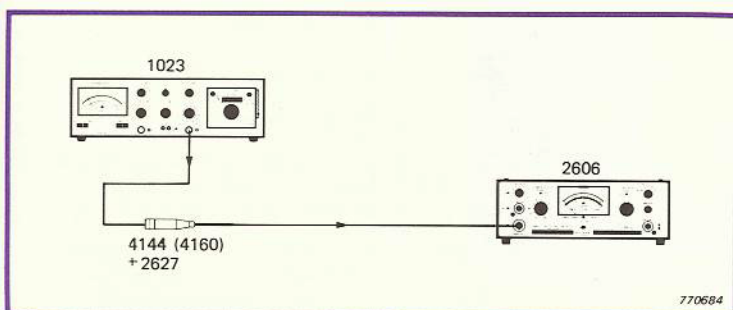



High Pressure, Low Frequency Calibration

Calibration at low frequencies and high sound pressure levels is necessary for measurements on jet engines, explosions, sonic booms, etc. Calibration may include sensitivity, frequency response, distortion and linearity measurements.

The High Pressure Microphone Calibrator Type 4221

The 4221 uses a small electrodynamic exciter to drive a large-area piston in a calibration cavity. Two couplers are delivered. The high pressure coupler can be fitted with one or two microphones. Sound pressure levels up to 164 dB SPL may be obtained in continuous operation over the frequency range 2 Hz to 1000 Hz. Using the Gating System Type 4440 for tone-burst excitation, levels up to 172 dB may be obtained. The low frequency coupler allows measure-

ments down to 0.01 Hz; for measurements at such low frequencies, the B & K Microphone Carrier System Type 2631 should be used.

An output socket is provided to monitor the excitation current, which is proportional to the sound pressure in the cavity. The 4221 is factory adjusted so that 1 mV at this socket corresponds to 20 Pa at 95 Hz. Frequency response curves are provided giving the correction to be used at other frequencies.

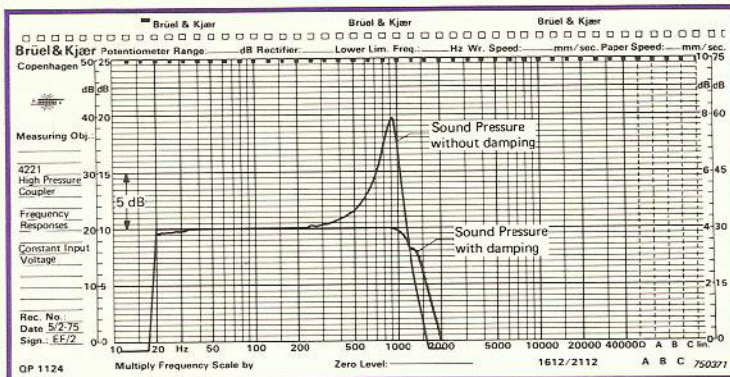

Frequency response of the High Pressure Coupler



Type 4221

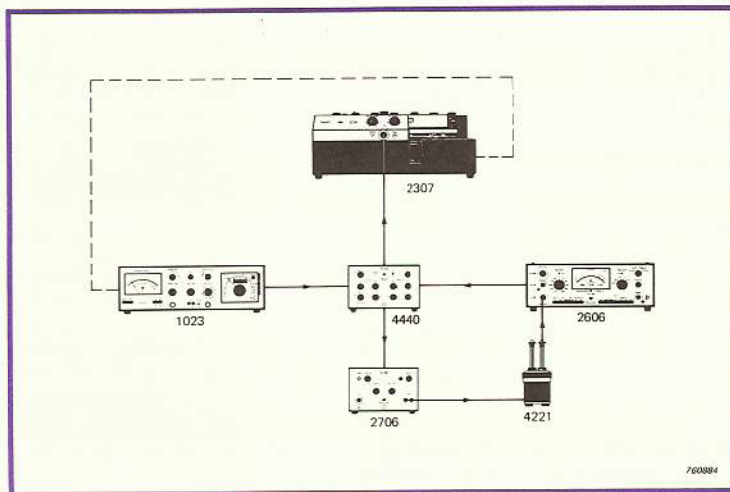

Set-up for measurements up to 172 dB SPL

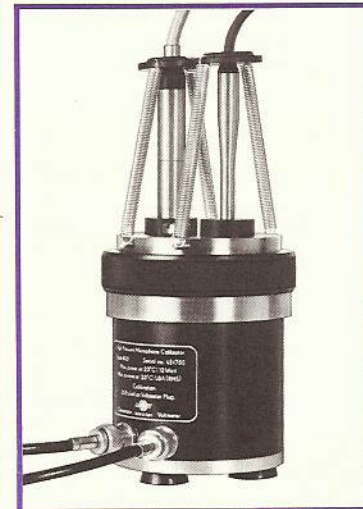



Electrostatic Actuator Measurements

If a metallic grid is placed close to the diaphragm of a microphone, an electrical potential difference applied between the grid and the diaphragm will induce an electrostatic force acting on the diaphragm in a similar way to a sound pressure. Since the magnitude of the force depends upon the distance between the diaphragm and the grid, absolute calibration is rather difficult and is not performed in practice. On the other hand, the Electrostatic Actuator method is the only practical method available for relative measurements such as frequency response, phase characteristics and pulse response measurements.

If the excitation signal includes both a DC bias voltage and an AC voltage of considerably lower amplitude, the force experienced by the diaphragm will be at the frequency of the AC signal. Alternatively, if only an AC voltage is applied, the frequency is doubled.

Two Electrostatic Actuators are available from B & K: UA 0023 for 1" microphone cartridges (except Type 4160) and UA 0033 for 1/2" cartridges and smaller microphones fitted with the appropriate adaptor.

Both Actuators are delivered with the Reciprocity Calibration Apparatus Type 4143. The 4143 delivers a bias voltage of 800 V DC and includes a 20 dB actuator amplifier to provide a sufficiently high AC excitation signal when used with the B & K Generators, which can deliver a max. output voltage of 10 V RMS.

Frequency Response Measurements

A typical set-up for automatic frequency response measurements is shown in the figure. With a 10V RMS signal from the Generator, the 4143 will deliver an AC excitation signal of 100 V RMS together with a bias voltage of 800V DC. This results in an equivalent sound pressure level of approx. 104 dB re. 20 μ Pa. The microphone output is recorded on a Level Recorder Type 2307. The Generator and Level Recorder are synchronized via a mechanical or electrical drive, allowing the frequency response to be automatically recorded on preprinted frequency-calibrated paper.

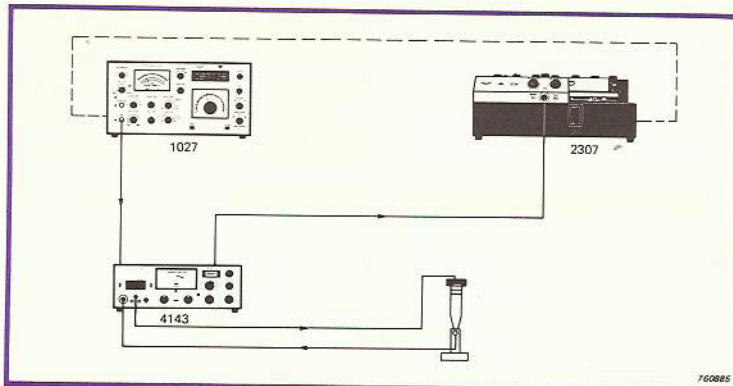

Set-up for recording microphone frequency response

The microphone and actuator can be located in a gas other than air, in a high pressure chamber or in a bell jar in order to investigate the microphone frequency response as a function of environment and static pressure.

The curve recorded using the Electrostatic Actuator method is close to the pressure response for microphones with a high diaphragm impedance (see B & K Technical Review No. 2-1969). If the free-field response is needed, the free-field correction curves of the microphone should be added to the actuator response. In the case of B & K free-field microphones, this is done on the calibration chart for 0° incidence.

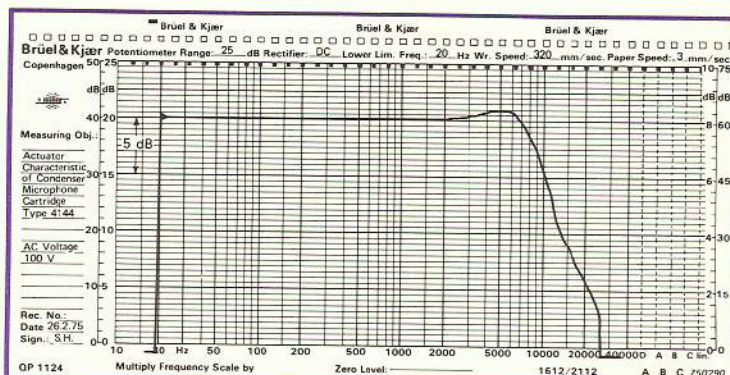

Typical frequency response of a 1" Condenser Microphone

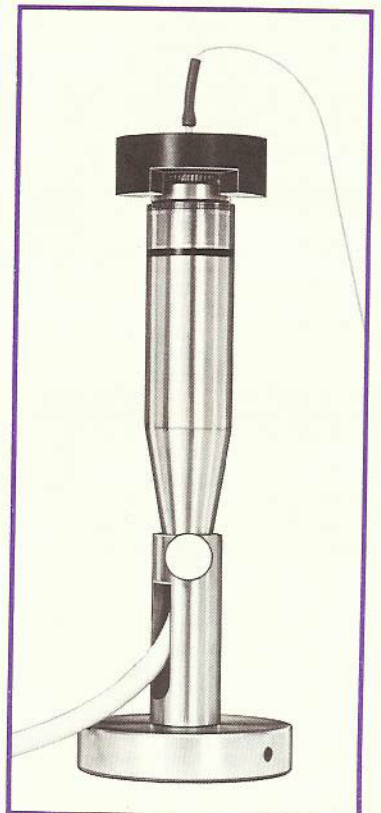
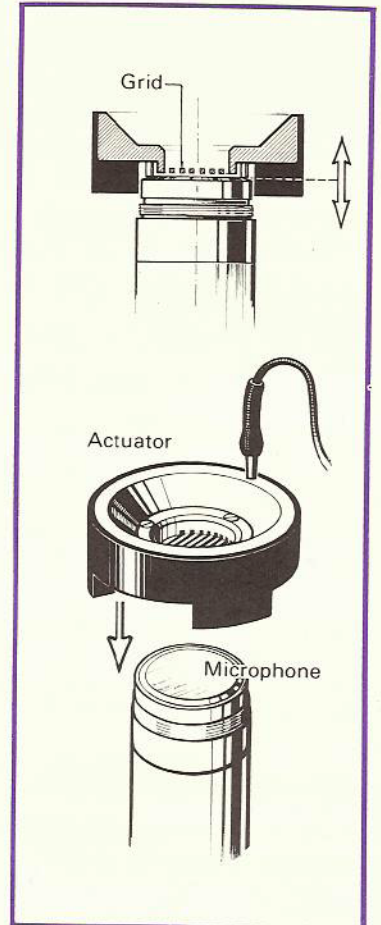

1" Microphone fitted with Electrostatic Actuator UA 0023



Electrostatic Actuator Measurements

High Resolution Measurements

Besides standard frequency response measurements, the 4143 allows high resolution measurements if use is made of the built-in precision comparator. The microphone output signal can be compared with a reference signal derived from the compressor output of the 4143 (proportional to the output of the actuator amplifier). Using this method at several point frequencies, the frequency response of a microphone may be measured with a resolution of 0,005 dB.

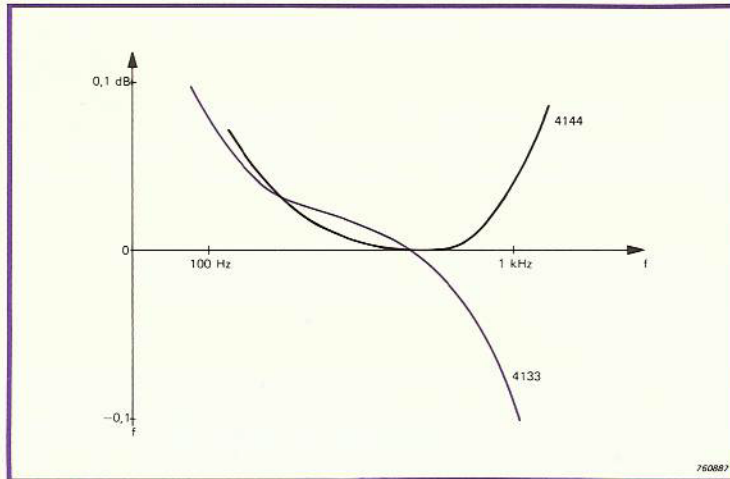

Phase Response Measurements

The Electrostatic Actuator method can be used for microphone phase response measurements in conjunction with the B & K Phase Meter Type 2971. The signal from the microphone is compared with the excitation signal. The DC output from the Phase Meter is fed to a Level Recorder Type 2307 where the phase response is recorded on frequency-calibrated paper.

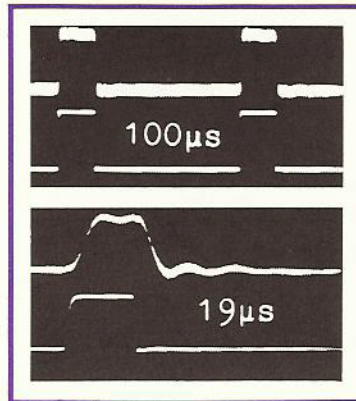

Microphone Transient Response

Using a function generator to drive an Electrostatic Actuator, the pulse response of a microphone can be evaluated, for instance on an oscilloscope, as illustrated in the figure.

Remote calibration of Outdoor Microphones



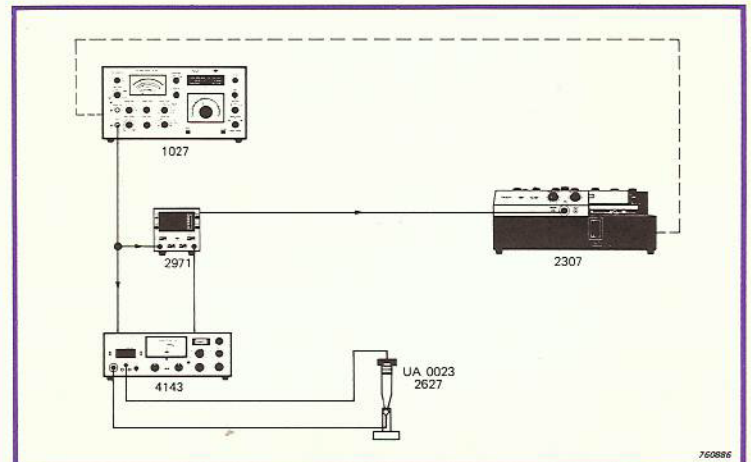
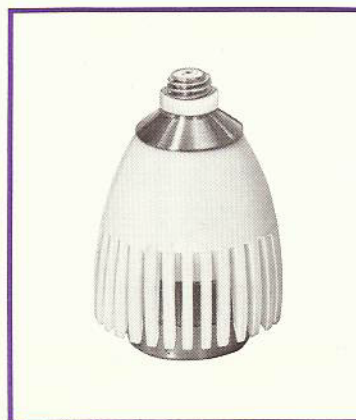



When 1/2" microphones are used in permanent outdoor systems, such as airport noise monitoring systems, the Rain Cover UA 0393 provides a convenient means for remote calibration checks. The Rain Cover features a built-in electrostatic actuator which can be factory calibrated with the microphone to provide an equivalent sound pressure level of 90 dB re. 20 μPa at 1 kHz when an AC voltage of 215 V at 500 Hz is applied to the actuator. The Rain Cover is part of the Outdoor Microphone Unit Type 4921.





Summary

There are many reasons for making acoustical measurements, but all practical applications have a basic requirement in common: if measurements are to be useful in resolving the problem faced by the investigator, they must be made with microphones which have suitable accuracy and sensitivity. Various calibration techniques have been described as well as the application of B & K instruments in calibration work. The table below summarizes the main applications of the instruments described.

	Instrument	Main Applications
	Reciprocity Calibration Apparatus Type 4143	Reciprocity Calibration of primary standards Coupler comparison calibration Frequency response measurements (Electrostatic Actuator)
	Pistonphone Type 4220	Point frequency calibration of microphones and complete systems. 250 Hz, 124 dB, $\pm 0,2$ dB accuracy
	Sound Level Calibrator Type 4230	Point frequency calibration of sound measuring systems. Particularly recommended for calibrations with weighting network switched in. 1000 Hz, 94 dB, $\pm 0,25$ dB accuracy
	High Pressure Microphone Calibrator Type 4221	High pressure, low frequency calibration. Up to 164 dB SPL in continuous operation and 172 dB in tone-burst operation. Frequency range down to 0,01 Hz.
	Electrostatic Actuator UA 0023 and UA 0033	Frequency response measurements Phase response measurements Transient response measurements
	Rain Cover UA 0393	Outdoor microphone calibration
	Condenser Microphone Type 4144 (4160) Insert Voltage Preamplifier Type 2627 Measuring Amplifier Type 2606	Primary standard for calibrating secondary standards and transfer standards

Literature





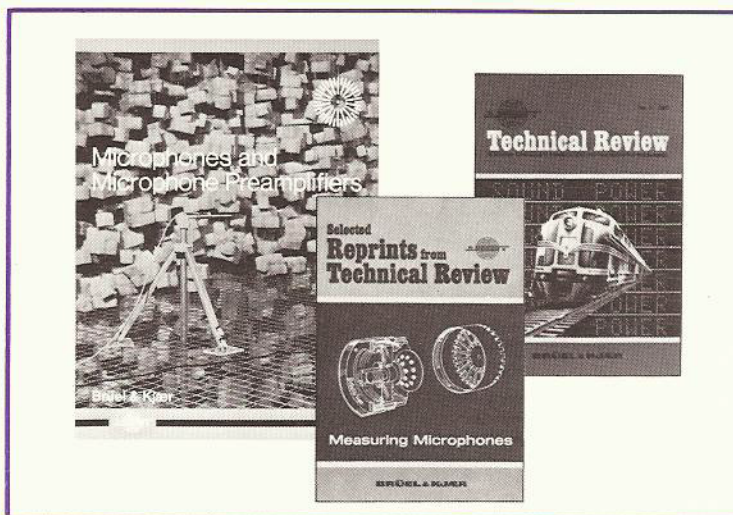





Use and application of each instrument is described in its own comprehensive Instruction Manual. Microphone calibration techniques are described in the handbook "Microphones and Microphone Preamplifiers" and in various articles published in the B & K Technical Review. The B & K Technical Review is a quarterly technical scientific journal reporting new advances in measurement technology. Selected reprints from the Technical Review have been grouped in a booklet entitled "Measuring Microphones" where different calibration methods are detailed. In addition, a number of "Lecture Notes" and "Exercises", as well as "Application Notes", are available.

All the above-mentioned literature is sent free of charge on request.



B & K Measuring Microphones

Condensed Specifications

Cartridge Type	Associated Preamp (Type No.)	Sensitivity* (mV/Pa)	Polarization Voltage (V)	Frequency Range** (± 2 dB)	Frequency Response	Dynamic Range*** (dB)	Diameter	1:2
4138	2618 UA 0160 or 2619 + UA 0036	1	200	6,5 Hz— 140 kHz	Pressure and Random	76 ^x —168	1/8"	
4135	2618 or 2619 + UA 0035	4		3,9 Hz— 100 kHz	Free Field	59 ^x —164	1/4"	
4136		1,6		3,9 Hz— 70 kHz	Pressure and Random	67 ^x —172		
4133 4163 4149	2619	12,5		3,9 Hz— 40 kHz	Free Field	29—160	1/2"	
4134				3,9 Hz— 20 kHz	Pressure and Random			
4147	2631 (with 2619 specs. as 4134)	3,7 — 18	None (10 MHz c.f.)	0,01 Hz— 18 kHz	Pressure and Random	64—150	1/2"	
4148	2619 with Type 2804	12,5	28	2,6 Hz— 16 kHz	Free Field	29—140		
4165	2619	50	200	2,6 Hz— 20 kHz	Free Field	19—146	1/2"	
4166				2,6 Hz— 9 kHz	Pressure and Random			
4144	2619 or 2627	50		2,6 Hz— 8 kHz	Pressure	2619: 12—148	1"	
4145 4161				2,6 Hz— 18 kHz	Free Field	2627: 10—148		
4160	2627	47		2,6 Hz— 8,5 kHz	Pressure	12—146	1"	
4146	2631 (with 2619 or 2627 spec. same as 4144)	12 — 60	None (10 MHz c.f.)	< 0,1 Hz— 8 kHz	Pressure	54—138	1"	
4117	Cable AO 0062 direct to Amplifier	3	None	4 Hz— 10 kHz (± 3 dB)	Free Field	upper limit 138	1"	
4125	2642 and in 2219, 4424 and 4425	10	28 (up to 140)	5 Hz— 12,5 kHz (± 3 dB)	Free Field and Random	upper limit 146	1/2"	

* 1 Pa = 1 N/m² = 10 μ bar

** Free field normal incidence (0°). For 4138 90° incidence. Lower limiting frequency valid for microphone, the actual limit depends on preamp. used

*** From A-weighted noise level to 3% dist. level re 0,00002 Pa

* Lin. Noise Level from 20 Hz to 200 kHz

